

Cleaning Technology · Municipal Technology

Hako
Clean ahead



Multicar M27compact

The new 3.5-t class!

For users holding a class-B driving license



Comfortable 2-seater cabin, space-frame design with tinted panoramic windscreen and an excellent all-round view – for more safety during operation.

Screwed, robust commercial-vehicle frame that can be upgraded with connection points for different superstructures or loading beds.

The compact 3.5-tonner – with a wide range of application options

The Multicar M27compact combines both the efficiency and flexibility of a multi-functional implement carrier and transporter with the comfort and reliability of a commercial vehicle. The vehicle's GVW of 3.5 t ensures that the Multicar can be driven by anyone holding a class-B driving license. Driving the vehicle is as comfortable as driving a modern motorcar: it is equipped with a 5-speed transmission, power steering and optional air conditioning. Its small width of only 1.63 m makes the vehicle perfectly suited for working in difficult-to-access areas – and for

every application, because quickly converting and up-grading the vehicle from a reliable transporter with a payload of over 1.0 t to a versatile implement carrier with both hydraulic and electrical work functions is particularly easy.



Developed and produced in Germany – quality "made in Germany"!



Class-B!

Provides a more flexible utilisation of your fleet: Thanks to its GVW of 3.5 t, the Multicar M27compact can be driven by anyone holding a class-B driving license. Perfect for any business, because this Multicar is a full-featured transport and working vehicle that does not require a truck driving license!





Saves time: With its top speed of 80 km/h, the Multicar M27compact can also be driven on motorways and express roads – for significantly reduced travel times from one job site to the next.

Just as you wish

Depending on your individual requirements and desired equipment, the Multicar M27compact offers different interfaces providing fast and easy changing of attachments: Front lift with attachment plate, connection points behind the cabin, rear mounts, electrical sockets and hydraulic couplings to drive and control the attachments.



Robust chassis with attachment points for interchangeable superstructures – from transport tippers, gritters and brine sprayers to water tanks equipped with pumps.

Detachable interface between the tipping cylinder and the tipper.

Electrical interface in the centre of the vehicle to connect and control the attachments.



Front lift with attachment plate for easy mounting of attachments – tool-changing quickly accomplished.



The comfortably spring-mounted independent suspension at the front axle ensures precise steering and excellent driving stability, particularly at high speeds and when working with front attachments.

Safe driving. Safe working!

The independent wheel suspension at the front axle provides both stable road-holding characteristics and comfortable driving. The Multicar M27compact is equipped with 4-channel ABS and disc brakes on all four wheels as a standard, which ensures short braking distances for increased safety.



Individually adjustable ergonomic seats with headrests – for safe and fatigue-free working in the cockpit.

All operating elements are within easy reach: Clearly arranged and easy to use – the control functions of the Multicar M27compact.



Everything under control with just one hand: The joystick allows the central control of attachment functions even in drive mode.



Multi-functional display: Everything at a glance

The information centre for the driver: Analogue displays indicating the speed, fuel level and water temperature. Plus digital displays for all operating functions such as hydraulic-oil temperature, the vehicle's operating hours or the hydraulic system. And what's more, the integrated digital clock ensures that the driver always arrives at the next job site on time.



Clearly arranged cockpit: All operating functions are in direct view of the driver.

Excellent workplace

Designed and manufactured to meet practical daily demands: Both the big panoramic windscreen and side windows in the lower door areas provide an optimal all-round view onto the traffic area and the attachments. The cabin has been designed to meet established ergonomic principles – all operating elements are within easy reach.



Occupational safety in every detail

Additional handholds and the non-slip design make entering the Multicar M27compact particularly comfortable. The cockpit is fitted with noise-reducing and insulating cladding, protecting both the driver and passenger from excessive working noises.

Maintenance made easy

All components are easily accessible for the service technician.



Front-, rear- or top-mounted: Maximal multi-functionality

The wide range of attachments available for various different applications ensures that the Multicar M27compact can cover a broad spectrum of operational tasks – with only one basic vehicle. Enabling

both efficient and economic working at any time, the Multicar M27compact is almost always ready for any task at hand.

All-season use? It goes without saying!

Just a few simple steps are required to convert the Multicar M27compact into a professional winter service vehicle. Or into a container transporter. Or into a safe lifting platform. Or even into a vehicle providing wet cleaning of large areas. Three attachment points as well as both electrical and hydraulic interfaces enable fast and easy retooling for any kind of seasonal work.



- | | | | |
|---|---|---|---|
| 
Gardening | 
Sweeping | 
Winter service | 
Wet cleaning |
| 
Waste management | 
Transport | 
Road maintenance | 
Special applications |

Technical data

Multicar M27compact	
Engine and transmission	
Engine	Volkswagen 4-zylinder turbo diesel
Displacement	1,968 cm³
Output	55 kW (75 HP) at 2,700 RPM
Max. torque	240 Nm at 1,750 RPM
Working properties (selectable)	
Hydraulics	tipper hydraulics control functions for front attachments 1 – 2 hydraulic drive circuits
Electrics	electrical interfaces front/centre
Attachment mount front	front lift with attachment plate
Attachment mount centre	tipper cross member, loading bed/ tipper superstructure
Attachment mount rear	rear bracket
Drive and steering	
Transmission	double synchronised 5-speed manual transmission with reverse gear
Drive options	selectable all-wheel drive with mechanical crawler gear, mechanical differential lock at the rear
Speed	0.6 – 80 km/h
Steering	front wheel steering
Tank capacity	90 litres
Braking system	hydraulic double-circuit braking system with 4 ventilated disc brakes, brake booster, 4-channel ABS, mechanical parking brake acting on the rear axle.
Load values	
GVW	3.5 t / 4.5 t
Empty weight	from 2.2 t
Basic vehicle	
Chassis	comfortably spring-mounted chassis, hydraulic vibration dampers, stabiliser at the rear
Frame	screwed commercial-vehicle frame with ball mounts for loading bed, tipper or superstructures
Front axle	steering axle, optional with steering drive axle, independent suspension with coil springs
Rear axle	drive axle, rigid axle with leaf springs and additional rubber springs
Tyres	225/75 R16C (summer/ winter), optionally 285/65 R16C
Cabin	2-seater comfort cabin, space frame de- sign, tinted panoramic windscreen made of laminated safety glass, doors with wind-up windows, additional windows in the lower cabin area

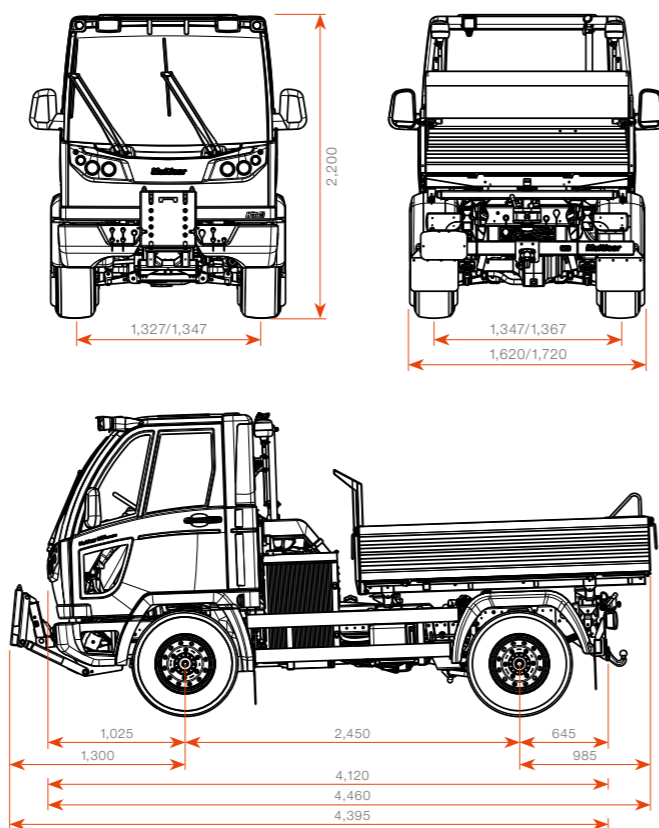

In the interest of further technical development we reserve the right to colour-, structural or design modifications. Pictures may show optional equipment.

Dimensions according to VO (EU) No. 1230/2012, depending on the equipment. Exact dimensions depend on the tyres selected.

We are there for you 24/7: Thanks to our close-knit sales and service network

Around 650 technicians are available all across Europe to service your Hako vehicles. Our dense service network has one key advantage: The workshop of one of our service partners is usually in your vicinity, ensuring that maintenance work can be carried out promptly and efficiently.

Hako Finance

Investing into modern implement carriers without straining your liquidity: This is possible with Hako Finance – customised leasing or rental models that meet our customers' individual requirements.



Our comprehensive network of authorised service partners: All over Germany and always close to our customers.



Hako's service for your investment: Liquidity-preserving leasing or rental models enable you to modernise your fleet of vehicles.



Dense service network, short distances: Significantly reduces downtimes due to necessary maintenance work. Because time is money.



650 technicians all across Europe – available 24/7.

Our experts for your vehicle.

Competent workshops with experienced technicians carry out all services on the vehicles. In addition, customers benefit from our maintenance-friendly technology, which reduces the time spent in the workshop to a minimum.





Cleanliness and safety
Our machines meet the
highest standards

Hako: Environmentally friendly right from the start

It is our legacy to leave behind a clean planet. That is why resources-, environmental- and climate protection characterise each and every process at Hako which has been certified by independent institutions. Learn more about our ongoing commitment at www.hako.com.

Everywhere and always close by

Our efficient sales & service network guarantees close proximity and rapid help.

Cleanliness combined with safety

Our machines meet the highest standards. Reliable quality "Made by Hako".

Buying, leasing, renting

We offer you a wide range of attractive individual financing and procurement options.

We are available 24/7

Hako's spare part express and on-call service guarantees best possible availability

BLUECOMPETENCE

Alliance Member

Partner of the Engineering Industry Sustainability Initiative

Hako GmbH
Head Office
Hamburger Str. 209-239
23843 Bad Oldesloe
Tel. +49(0)4531-806 0
info@hako.com
www.hako.com