

Cleaning Technology · Municipal Technology

Hako

Clean ahead



The new Multicar M31 Euro VI
Multi-functional professional
implement carrier & transporter

Ergonomic. Eco-friendly. Powerful.



Everything drivers have always wanted

The Multicar M31 sets new standards, combining multi-functionality and manoeuvrability with the highest safety standards and comfort for the driver. The ergonomically optimized design of the cabin, equipped with unique DEKRA-approved safety features, guarantees a level of driving pleasure and fatigue-free working that is of mutual benefit for both your company and your staff. Variable and efficient: Three attachment points provide for more than 300 different equipment combinations – with quick-change system at the front and ball-mount at the rear. The powerful, low-consumption turbo diesel engine provides just the right drive, making the Multicar M31 your number-one choice if you are looking for an implement carrier and a transporter all in one vehicle!



Powerful:
Gross combination
weight max. 7.5 t

Windscreen
with integrated
sun-glare filter

Optimum view
of the equipment
and tools

Multicar M31
with bi-halogen lights and
LED daytime lights

Ergonomic: cabin and
operating elements for
fatigue-free working

Safe: ventilated
4-wheel disc brakes
and 4-channel ABS

Multicar M31: variable with
short or long wheelbase
and 4x2 or 4x4 drive

Multicar M31 B with skip loader

Optimized technology – appealing design

Powerful technology – makes work easier and more comfortable

Flexible employment

Three attachment points room for more than 300 tailor-fitted implements make the Multicar M31 the perfect multi-functional vehicle. The front mounting plate SWV 500 with integrated lifting device facilitates employment of efficient front-mounted equipment. Thanks to the ball-change system, the M31 is as flexible in the city as it is in the open country for all-year-round use.

Economic-efficient operation

Investing in the Multicar M31 pays off quickly. The flexible, high-quality light-weight steel frame ensures a long service life – in non-stop operation. The powerful, low-maintenance engine is extremely economical, leading to considerable savings in terms of operating costs. A top speed of 90 km/h ensures short transit time to the job site for profitable employment. Low maintenance costs further add to the vehicle's many advantages.

Comfortable day-to-day working

When designing the Multicar M31, it was our goal to make work easier for you. With its width of only 1.63 metres, the small turning circle and equipped with power-assisted steering as a standard, the vehicle gets you everywhere. You can choose between a 4x2 and a 4x4-drive. All-wheel-drive and crawling gear can be switched-on if required. Please also view pages 6/7 for further details.

Quality made in Germany

Multicar has been developed and produced in Germany for more than 50 years.



Variable hydraulic system:
From simple tipper hydraulics to stationary hydraulics and mobile hydraulics with comfort control, switchable to high-pressure hydraulics



Service- and maintenance-friendly – all parts of the tilting cabin and the 3-way tipper are easily accessible



Three different attachment points, front-mount quick-change system with lifting and lowering functions for easy loading of various front-mount devices



Modern, ergonomically designed space-frame cabin with optimal view of the traffic and the implements, cabin suitable for 2-3 passengers (also view pages 8/9 for further details).



Tipper superstructure ball-mounted on cross beams, ball-change system for quick mounting/dismounting of superstructures components



Gross combination weight up to 7.5 t, payload up to 3.1 t and brake assisted trailer load/ permissible trailer weight of up to 3.5 t

FPT turbo diesel engine with 110 kW (150 HP). A selective catalytic reduction system (SCR) provides emission control. The combination of particle filter and SCRT system reduces nitrogen oxides by over 90 % and particles by over 95 %

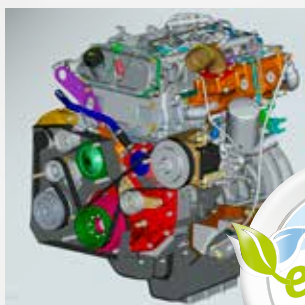

Balanced driving- and safe road holding characteristics – whether fully loaded or empty – due to an independent suspension with coil springs at the front and progressive flat springs with telescopic shock absorbers at the rear



These four models master the most demanding challenges

The new Multicar M31 is available in four different basic models. Thanks to the modular Multicar vehicle concept, you can choose from various equipment options and features to meet your individual requirements. Depending on the basic model, you can decide for a short or a long wheelbase, 4x2 or 4x4 drive, 2-seater or 3-seater cabin and choose from more than 20 additional options. Only one thing is clear from the very start: you get top-quality and service for a price that pays off in the long run.



Multicar M31 T*

Manual transmission

- the special transporter
- with budget-friendly tipper hydraulics for 3-way tipper
- tipper with a tipping angle of ca. 45° in all three directions and raised front & side boards as an option
- frame with four ball-points to mount the 3-way tipper
- optionally available with either 4x2 or 4x4 drive and short (2,450 mm) or long (2,995 mm) wheelbase
- preparation for light winter services available as an option
- flexible and powerful employment with payloads of up to 2.9 t and a trailer load of up to 3.5 t

*) These versions are equipped to comply with the Euro VI emission standard.



Multicar M31 B*

Manual transmission

- the basic model with robust chassis for a wide range of applications
- with stationary single-circuit hydraulics with gear pump for up to 200/250 bar nominal pressure
- particularly suited to operate stationary superstructures such as:
 - skip loaders and roll-off skips
 - loading cranes
 - aerial work platforms
 - waste compactors
 - gully cleaners
- optionally available with either 4x2 or 4x4 drive and short (2,450 mm) or long (2,995 mm) wheelbase
- optionally available with ball-change system for quick mounting and demounting of superstructures

Multicar M31 C*

Manual transmission

- the professional implement carrier with powerful mobile hydraulics, available in three different versions:
 - 1 work circuit with gear pump
 - 2 work circuits with double gear pump
 - 2 work circuits with axial piston pump (high-pressure comfort hydraulics)
- for a wide range of demanding applications
- hydraulics volume flow infinitely adjustable, directly from within the cabin
- LS hydraulics for a high drive output at low rpm's
- with 4x4 drive, optionally available either short (2,450 mm) or long (2,995 mm) wheelbase
- optionally available with ball-change system for quick mounting and demounting of superstructures

Multicar M31 H

Hydrostat

- two infinitely adjustable speed levels and 4x4 drive for exact manoeuvring
- road use 0-70 km/h, in work-travel mode with mechanical crawling gear 0-40 km/h (hydraulically operated up to 34 km/h)
- combining the two crawling gears allows adjusting the work-travel speed between 0-17 km/h
- automotive speed can be regulated either via foot pedal or proportionally via control lever and gas-inch pedal with electronic work speed control

See Multicar M31 Hydrostat brochure for details.



All models are also available as right-hand drive.

Cross-country mobility and certified safety

Equipment you can rely on



Certified all-round safety

The cabin of the Multicar M31 offers a kind of safety for the driver and the front seat passenger that is second-to-none in this vehicle class. The space-frame construction with special high-strength profiles is brand-new and DEKRA certified:

- Cabin certified according to ECE-R-29 directive for the "Occupant protection in cabins of commercial vehicles" – front-end collision test (test A) and cabin roof stability test (test C) passed.
- Double-walled doors with steel and plastic are stress-test-approved, the test simulates 10 years of operation by opening and closing the doors 20,000 times.
- Seat belt mounting certified according to directive ECE-R-14 and 76/15 EC

All-terrain vehicle

The new Multicar M31 is both city and cross-country compliant. With its driver-engaged 4x4 drive, crawling gear and differential lock, the vehicle masters steep inclines in the country or on forest trails and convinces with excellent climbing power on slopes or building sites. Non-slip cross-country tyres ensure perfect traction. And in difficult situations you can fully rely on the 4-wheel ventilated disc brakes and the 4-channel ABS system. The Multicar M31 with hydrostatic drive enables comfortable driving and precise working at a very low speed.



The ergonomically designed space-frame cabin

A work place with new perspectives



At the push of a button

Electric windows (optional) and adjustable mirrors left and right

Everything under control

Optimal view of the traffic and the implements



More room

Glove box with gas spring and bottle holder provides more stowage space and keep things tidy



Everything within reach

Centralized operating & control elements:

- Switches with LED technology for a better overview
- 4-level heating and ventilation system for optimal air-flow in the entire cabin and the leg area



Head-room for the driver = 130 mm unloaded, plus 34 mm with flat seat

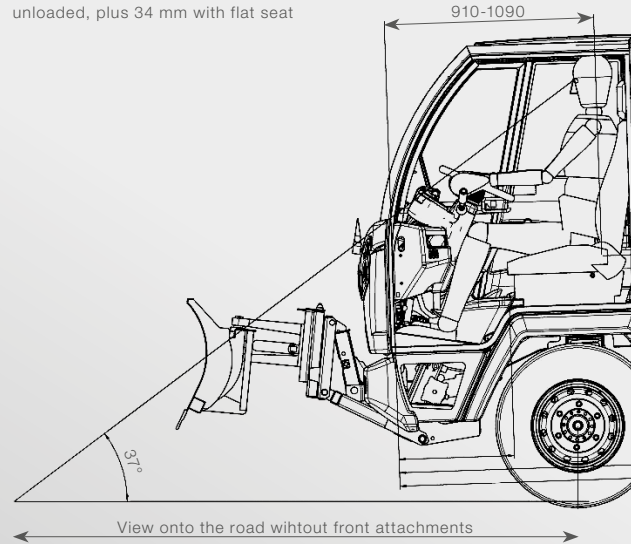

More room, a better view, increased safety

The ergonomically designed space-frame cabin ensures completely safe working. The panoramic windscreen with integrated sun-glare filter offers a superb all-round view and an increased view – plus 0.5 metres compared to its predecessor – of the front-mounted devices. Thanks to the big wind-up windows, newly arranged wipers and windows in the lower door area, the driver truly has everything under control. While we haven't changed the vehicle's compact external dimensions, the cabin space has increased by 4 cm in width and another 5 cm in the leg area.



Sophisticated details

- mobile hydraulics control integrated in the collapsible armrest

Optionally available

- 2-seater passenger bench
- mechanically sprung seat
- seat with integrated seat belt
- air-sprung seat
- MP3 Bluetooth radio with hands-free system



Individually adjustable

The Multicar has been designed for frequently changing drivers:

- variably adjustable seats
- seat belt height adjustment
- height- and angle-adjustable steering column

Diversity you will only find in a Multicar

Variable employment

Just as you would expect from a Multicar, the Multicar M31 offers a wide range of applications. An implement carrier you can always rely on – whether employed in the city, in the landscaping sector, on the building site or in waste management.

In addition to increasing the hydraulic output to 110 l and 144 l respectively, Hako's engineers have paid particular attention to increasing the front axle load – now up to 2.7 t – of all Multicar M31 Euro VI implement carrier versions to provide more reserves when operating front attachments. Furthermore, the vehicle's inherent protection has increased significantly by protecting it against hydraulic pressure peaks and external loads.

All-year-round employment

- for transport work requiring a 3-way tipper or a skip loader
- also in combination with a loading crane or gripper
- waste disposal tasks in pedestrian areas, parks and areas with narrow driveways or access-roads
- repair & maintenance work requiring an aerial work platform
- cleaning of gullies using a shaft-trolley construction
- Sewer cleaning with sewer-draining or suction/jetting devices

Seasonal employment

- winter service with snowploughs or snow front brooms and snow blowers with Multicar M31 H
- sweeping with front brooms and vacuum sweepers
- cleaning with water pressure or hand-held cleaning and watering devices
- mowing with mowing bars, sickle mowers, mallet mowers, mowing booms and mowing/suction combi devices
- tree & copse maintenance, tree pruning requiring an aerial work platform, wood chipping and transport of the cuttings

Additional swivel functions at the front and rear provide even more functionality when operating implements. The oil volume is adjustable to guarantee optimal adaptation to additional tools. The swivel function can also be utilised for a permanent consumer to increase the range of applications.





One for All
Go Multifunctional



Individualized optional equipment

We customize the Multicar M31 to suit your requirements perfectly

Every Multicar M31 is very well equipped as a standard – but you can add some individual extras, customizing your vehicle to suit your needs exactly. Every extra has been tailor-made for the Multicar M31 and is therefore a perfect fit in terms of compatibility and functionality. One thing is for sure: you and your staff will appreciate every practical extra that enhances your vehicle's performance and comfort even more.



Right-hand drive

optionally available for all vehicles



3-seater with front bench

for 2 passengers instead of a single front seat



Air-sprung seat

with seat heater and lumbar support



Driver's seat with integrated seat belt



Work light

integrated in the new height-adjustable light beam



Flashing beacon (LED)

and rear work light



Front fog lights (LED)



3-pin socket

e.g. for marker lights of front-mounted devices



Windscreen heater

for a clear view in the cold season



Air conditioning

integrated in the operating panel



Electric window-opener and mirror adjustment

left and right



Bluetooth radio

optionally flush-mounted in the roof console



Tow ball/bolt coupling

max. tow ball load 150/250 kg



Ball-change system

for easy mounting/dismounting of superstructures



Differential lock, 4x4 and crawling gear

at the touch of a button



Trailer tipper hydraulics

switch within easy reach

Tyres

The Multicar M31 is equipped with 225/75 R 16 C summer tyres as a standard. Additionally, a wide range of tyres is available to meet your individual requirements:

- 225/75 R 16 C All-season tyres (M&S)
- 225/75 R 16 C Winter tyres (M&S)
- 285/65 R 16 C All-season tyres (M&S)
- 315/55 R 16 Cross-country tyres (M&S)
- 325/60 R 15 Wide-base tyres, low ground pressure



Quality in line with sustainability

Purchasing a Multicar means that you have decided to go for top-quality and integrated sustainability. Our ultra-modern cathodic dip coating system, employing environment-friendly water-based paint, overlap-sealing

and additional underbody protection guarantees a premium coating quality as well as superb corrosion protection, resulting in a long vehicle service life.



Frontlift system SWV 500

with integrated lifting device for easy one-man changing of implements



RAL colors

We paint the Multicar M31 in the colour of your choice.

According to Euro VI standard



Environmentally friendly

The SCRT exhaust gas purification system (catalytic converters and particle filter) combined with the low-noise FPT high-volume series turbo diesel engine ensures best possible reduction of emissions and unpleasant smells

- Reduces nitrogen oxide emissions by more than 90 %
- Reduces particle emissions by more than 95 %
- Depending on the operating conditions, the common-rail injection system saves up to 10 % of fuel in comparison to the Euro V models.

Economic

In addition to the machine's ergonomic operability, for example the multi-functional colour display offering intuitive handling, power steering, cruise control and independent suspension for high levels of driving comfort and superior cross-country mobility, the vehicle is equipped with a number of assistance systems, helping the driver to manage his many different tasks. Including, for example:

- Work hydraulics can be adjusted via turn-push regulator
- Engine-hydraulic tipper function for both carrier vehicle and trailer
- Hydraulically tiltable cabin

Dimensions Multicar M31 Euro VI

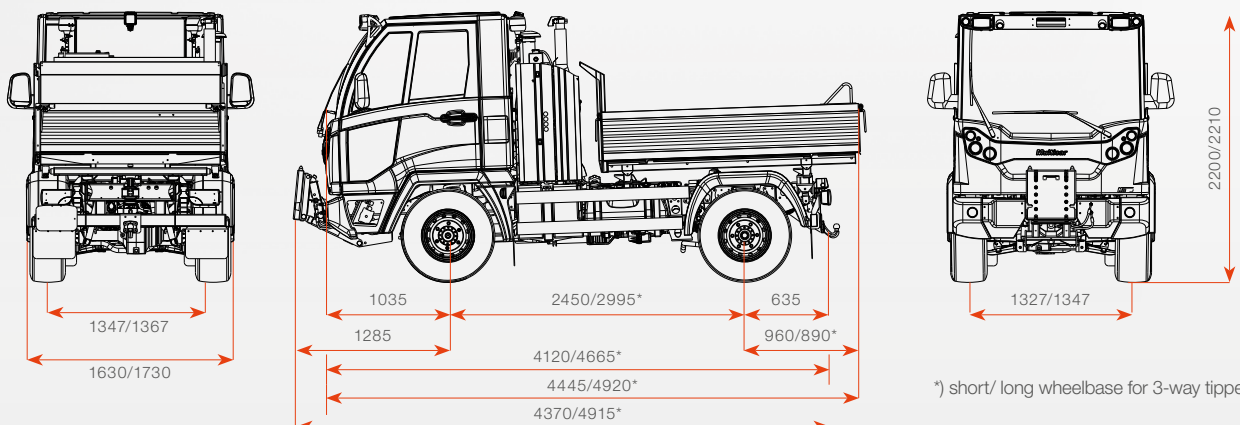

Technical Data

	Multicar M31 T Euro VI	Multicar M31 B Euro VI	Multicar M31 C Euro VI	Multicar M31 H
Engine and transmission				
Engine	High-volume series engine, FPT turbo diesel, Cubic capacity 2,998 cm ³			FPT F1 C turbo diesel Cubic capacity 2,998 cm ³
Performance	Engine with 110 kW (150 HP)			90 kW (122 HP)
Max. torque	320 Nm at 1,200 RPM			310 Nm at 1,250 rpm
Exhaust emissions	according to Euro-VI standard EC 595/2009/EC			accord. to 97/68/EC, level IIIB
Transmission	5 forward gears and 1 reverse gear; models with all-wheel drive incl. crawling gear: 10 forward gears and 2 reverse gears			Two-level hydrostat
Handling characteristics				
Speed range class N2	0–90 km/h			0–70 km/h
Chassis	Light-weight steel frame in a modular design			<ul style="list-style-type: none"> Hydraulic drive mode: 0-70 km/h Hydraulic work mode: 0-34 km/h Crawling gear level 1: 0-40 km/h Crawling gear level 2: 0-17 km/h
Wheelbase	2,450 mm (short) or 2,995 mm (long)			
Axles/suspension front	Independent suspension with telescopic shock absorbers and additional coil springs			
Axles/suspension rear	With telescopic shock absorbers and additional progressive leaf springs			
Tyres	225/75 R 16 C (standard), other tyres optionally available			
Cabin	Tiltable space frame cabin			
Drive and control unit				
Drive	4x2, selectable 4-wheel drive optionally available		Selectable 4-wheel drive (standard)	
Clutch	Hydraulically operated, asbestos-free			
Steering	Power steering (hydraulic), height and angle adjustable			
Tank capacity	90 l			80 l
Brakes	4-wheel disc brakes (ventilated) with 4-channel ABS			
Weights				
GVW	up to 5.6 t			up to 5.7 t at 70 km/h
Permissible axle load front	2.4t/2.7 t			2.4t
Permissible axle load rear	up to 3.67 t			up to 3.8 t
Max. payload 4x2 drive*	up to 2.9 t (short wheelbase) up to 2.8 t (long wheelbase)	Equipment and model dependent	-	-
Max. payload 4x4 drive*	up to 2.8 t (short wheelbase) up to 2.7 t (long wheelbase)	Equipment and model dependent	Equipment and model dependent	Equipment and model dependent
Permissible trailer weight	3.5 t (brake assisted) / 0.75 t (brake non-assisted)			
Gross combination weight	7.5 t			
Hydraulics	Tipper hydraulics: max. 10 l/min, max. work pressure 180 bar Optionally: pre-installed fittings for light winter service equipment (swivel/ lifting/ lowering functions front attachment – max. 5 l/min)	Stationary hydraulics Single-circuit hydraulics 40 to 55 l/min Work pressure 200/250 bar (depending on the model)	Mobile hydraulics 3 different versions available 1. 1 circuit, gear pump 1x 55 l, max. work pressure 200 bar 2. 2 circuits, double gear pump - 2x 55 l, max. work pressure 200/250 bar 3. 2 circuits, high pressure comfort hydraulics, axial piston pump and gear pump, 110 l + 34 l, max. work pressure 300/200 bar, switchable	<ul style="list-style-type: none"> LS universal hydraulics with two work circuits, max. 80 l/min. max. work pressure 200 bar or LS high-pressure comfort hydraulics with max. 80 l/min. max. work pressure 300/200 bar – switchable optional: power hydraulics summation circuit max. 110 l/min

Form, colour and design of our products are subject to change in favour of further technical developments. Pictures may show optional equipment.

* additional equipment reduces the payload



Hako: environmental-friendly right from the start

It is our legacy to leave behind a clean planet. That is why resources-, environmental- and climate protection characterize each and every process at Hako which has been certified by independent institutions. Learn more about our on-going commitment at www.hako.com

Close to you wherever you are

Our efficient close-knit sales & service network guarantees close proximity and rapid help.

Buying, leasing, renting

We offer you a number of individual and attractive financing & procurement options.

We are available 24/7

Hako's spare part express- and on-call service guarantees best possible availability.

BLUECOMPETENCE
Alliance Member

Partner of the Engineering Industry Sustainability Initiative



Hako GmbH
Head office
Hamburger Str. 209-239
23843 Bad Oldesloe
Tel. +49 (0) 4531-806 0
info@hako.com
www.hako.com