



Instruction Manual

Sweepmaster P1500 RH (6464.10)
Sweepmaster D1500 RH (6464.30)

Introduction

Preface

Dear Customer,

We are certain that the excellent qualities of the vehicle will justify the faith you have shown in us through your purchase.

Your safety, and that of others, basically lies in your ability to control and operate the vehicle. Before using the equipment for the first time, read this original manual thoroughly, act according to the information contained and keep it in a safe place for future reference or subsequent owners. Please read the Chapter "Safety Information" prior to starting the vehicle to ensure it is operated and used safely.

The operating manual contains all the most important information regarding operation, maintenance and service. Throughout this operating manual, sections which concern safety are indicated by corresponding warning symbols. Should you have any questions in respect of the vehicle or operating manual, your authorized Hako dealer is available to provide help at any time.

Please be expressly advised that you cannot base any legal claims on the information contained in this manual. Ensure only original spare parts are used should any repairs be necessary. Only such original spare parts warrant that the equipment is reliably ready to use at all times. Subject to modification as required by technical advancement.

Valid as of: April 2014

Hako GmbH
D-23843 Bad Oldesloe
Hamburger Str. 209-239
Phone ++49 (0) 4531 8060

Proper use

The Sweepmaster is a sweeping intended for commercial use and has been exclusively designed for sweeping up dry and wet refuse from areas such as production plants, warehouses, car parks and pedestrian precincts. Any use beyond this is regarded as improper use. The manufacturer is not considered liable for any damage resulting from improper use; the user is solely responsible for all the risks. The sweeping

vehicle must not be used to clear up toxic, inflammable or other substances which represent a potential health hazard. Intended use also includes maintaining and observing the operating, maintenance and repair conditions prescribed by the manufacturer.

The Sweepmaster may only be operated, serviced and repaired by personnel who are familiar with the work involved and are aware of the risks.

Based on the conception, design and construction of the model introduced onto the market by us, the machine complies with the applicable basic safety and health requirements stipulated in the EC Directive (refer to Declaration of Conformity). This declaration is no longer considered valid in the event of modifications to the machine not authorized by us. The manufacturer is not deemed liable for any damage resulting from unauthorized modifications to the machine.

Introduction

Notes on warranty

The terms defined in the purchase agreement apply. Claims for compensation related to damage are excluded from the terms of warranty when the damage is the result of failure to observe regulations concerning service and maintenance. Maintenance work must be performed by authorized Hako service centers and confirmed in the "Maintenance Report" which serves as a warranty logbook.

The following are excluded from the terms of warranty: wear and tear through overuse, defective fuses, improper handling and use or unauthorized modifications. Claims under the terms of warranty are also annulled when damage occurs to the vehicle resulting from the use of parts or accessories not explicitly approved by us or from failure to observe maintenance regulations.

Acceptance of the machine

Inspect the vehicle immediately on delivery for signs of transport damage. Replacement will be made when confirmation is provided immediately by the freight carrier with regard to the damage and the damage report is sent to

our authorized sales partner together with the consignment note.

Disposing of the machine

Render the machine inoperable. It must not represent a source of risks to children. Dispose of the machine in accordance with the applicable local regulations. For further information on disposal and recycling, contact the authorized Hako dealer where you purchased the machine.



Used batteries with the recycling symbol contain reusable commodities. The heavy metals contained simultaneously represent a serious risk to health and to the environment. Never open batteries or damage them. Never touch, inhale or swallow any material inside batteries. Health hazard! Never allow batteries to pollute the environment. Risk of contaminating the ground and water! In accordance with the symbol with the crossed out bin, these batteries must not be disposed of in domestic waste. The return and recycling of old batteries must be agreed on with your authorized

Hako dealer in accordance with the Battery Law § 6 and § 8 (BattG).

Regulations for approval

The Sweepmaster is an automotive machine within the terms defined in the Road Traffic Licensing Regulations (FZV §2, previously StVZO §18).

On request, the manufacturing plant can enclose a report with which to acquire the vehicle type approval. This report is used by the local vehicle registration office to produce a valid vehicle registration license (Vehicle Registration Certificate, Part 1).

An official license number is not necessary. A general inspection in accordance with § 29 StVZO (road traffic licensing regulation) is not required either because the vehicle is designed for a top speed under 20 kph. In accordance with the StVZO, the vehicle must carry a first-aid kit, warning triangle and the vehicle registration license when used on public roads, paths and pedestrian precincts.

If any attachments or conversions are made on the Sweepmaster, which affect the equipment described in the vehicle registration license and are not mentioned in the vehicle registration li-

Introduction

cense, the license becomes invalid. To acquire a new vehicle registration license, the vehicle must be presented to an officially accepted expert to produce a new report. The report becomes the official vehicle registration license when the vehicle registration office applies the applicable stamp.

Driving license

In accordance with the provisions on driving licenses, a person who intends to drive a motor vehicle constructed with a top speed in excess of 6 kph on public roads, paths and pedestrian precincts, must be in possession of a valid driving license. Drivers of the Sweepmaster require a driving license for automotive agricultural machines up to 25 kph (Class L or higher).

Table of Content

Introduction	2	2.7	Transporting	28	5.6.3	Cleaning the main filter	58	
Preface	2	2.8	Towing the vehicle	28	5.6.4	Installing the main filter	58	
Intended use	2	3	Operation	29	5.6.5	Changing the main filter	58	
Notes on warranty	3	3.1	Method of operation	29	5.6.6	Changing the safety cartridge	58	
Acceptance of the machine . . .	3	3.2	Operating elements	30	5.7	Cooling system	59	
Conditions for approval	3	3.2.1	Operating panel A	30	5.7.1	Cleaning the radiator	60	
Driving license	3	3.2.2	Operating panel B	34	5.7.2	Refilling the coolant	60	
Disposing of batteries	4	3.2.3	Operating elements on the ma- chine	36	5.7.3	Changing the coolant	60	
1	Safety Information	7	4	Technical Data	40	5.8	Hydraulic system	61
1.1	Safety and warning symbols . .	7	5	Maintenance and Care	45	5.8.1	Filling hydraulic oil	62
1.2	General information	8	5.1	Hako System Maintenance . .	45	5.8.2	Changing the hydraulic oil . .	62
1.3	Operating information	8	5.2	Maintenance report	46	5.8.3	Change hydraulic oil filter . .	62
1.4	Maintenance information . . .	10	5.3	Maintenance plan	47	5.9	Sweeping unit	63
1.5	Particular risks	11	5.4	Seat console	54	5.9.1	Side brushes	64
1.6	Environmental protection . . .	12	5.4.1	Opening the seat console . .	54	5.9.2	Adjusting the side brushes . .	65
1.7	Labels on the vehicle	13	5.5	Engine	55	5.9.3	Changing the side brushes . .	65
2	Operation	17	5.5.1	Refilling the engine oil	56	5.9.4	Rotary brush	66
2.1	Instruction	17	5.5.2	Changing the engine oil and oil filter	56	5.9.5	Setting the sweeping pattern	67
2.2	Prior to starting up	18	5.5.3	Changing the fuel filter	56	5.9.6	Aligning the rotary brush parallel	67
2.3	Starting the engine	19	5.5.4	Venting the fuel system	56	5.9.7	Changing the rotary brush . .	67
2.4	Stopping and switching off the vehicle	22	5.6	Air filter	57	5.9.8	Adjusting the sealing strips .	68
2.5	Sweeping operation	23	5.6.1	Cleaning the dust discharge val- ve	58	5.9.9	Changing the sealing strips .	68
2.5.1	Emptying the sweepings container	24	5.6.2	Disassembling the main filter	58	5.9.10	Filter system	69
2.6	Function faults	26				5.9.11	Cleaning the dust filter	70
2.6.1	Service code table	26				5.9.12	Changing the dust filter	70
						5.10	Wheels and brakes	71

Table of Content



5.10.1	Checking tire wear	71
5.10.2	Changing tires	71
5.10.3	Brakes	71
5.11	Electronics	72
5.11.1	Fuses	72
5.11.2	Relays	73
5.11.3	Changing the battery	73
5.12	Special equipment and replacement demands	74
	EC Declaration of Conformity	
	75	

Safety Information

1 Safety Information

1.1 Safety and warning symbols

All sections related to personal safety, safety of the vehicle and environmental protection are assigned the following symbols throughout the operating manual:

Symbol	Risks to ...	Definition
Safety information 	persons or property	Safety information on preventing hazardous situations caused by failure to follow instructions or prescribed working procedures accurately or at all.
Note 	the machine	Important information on handling the equipment in order to maintain its functionality.
Ecological hazard 	the environment	Ecological hazard through the use of substances which represent a potential hazard to health and the environment.

Safety Information

1.2 General information

- Apart from the provisions contained in this instruction manual, the general safety provisions and the accident prevention regulations as imposed by law have to be complied with.
- Before taking your machine into operation, carefully read the instruction manual and comply with all points mentioned there during work.
- Persons being trained by qualified Hako technicians only are authorised to operate, service and repair the machine.
- This vehicle is not intended to be used by persons (including children) with limited physical or mental capabilities or persons without sufficient experience and ability.
- You are advised to thoroughly study the safety instructions since precise knowledge only helps avoiding errors during operation of the machine and thus guarantee faultless usage of the machine.
- The operating instructions have to be at hand at the place of use of the machine, and therefore have to be kept readily available at the machine.
- When selling or letting the machine for rent, hand out these documents to the new owner/operator and have the transfer certified!
- The warning and instruction plates attached to the machine contain valuable advice about safe operation. Immediately replace incomplete or illegible labels.
- As far as safety standards are concerned, spare have to equal genuine spare parts!
- Keep clear of hazard zone of the Sweepmaster.
- Only use a mobile phone when the machine standing still.
- Passenger transport is not admitted.

1.3 Operating information

- Check the operational safety of the vehicle each time before starting it up! Clear any faults immediately!
- Before starting work, the operator must be fully familiar with all adjustment, operating and control elements as well as their respective function! It is too late to do this when the vehicle is actually in operation!
- Always wear heavy duty, non-slip footwear when working with the vehicle.

cle.

- The vehicle may only be driven on and the equipment used on those surfaces which have been approved by the contractor or person appointed by him.
- When using the vehicle, it is essential to pay attention to third parties, especially children.
- The vehicle is not suitable for clearing up hazardous, inflammable or explosive fluids, dust or substances.
- This vehicle must not be used as dust cleaner equipped with a dust filter insert (dust collector) to clear up dust which could represent a hazard to health.
- It is forbidden to use the vehicle in potentially explosive atmospheres.
- Remove the ignition key to prevent unauthorized use of the vehicle.
- The vehicle and its equipment must be checked in terms of perfect working condition and operational safety before being put into use. The vehicle must not be used if it is not in a proper working condition.
- Before putting the vehicle into operation, adjust the driver's seat so that you have a perfect view of the front

Safety Information

and rear path of travel and working area!

- For safety reasons, the driver's seat is equipped with a seat contact switch. The engine can only be started when the operator is sitting on the driver's seat. The function of the seat contact switch must not be bypassed.
- The seat contact switch is monitored electronically. Any attempt at manipulation can lead to the vehicle being automatically locked against use.
- Always switch off all the drives before starting the engine.
- The vehicle must only be started, put into motion and stopped from the seat.
- Do not allow the engine to run in closed rooms! Risk of poisoning!
- Ensure there is sufficient ventilation when sweeping in closed spaces (dust and exhaust fumes). Risk of poisoning!
- The driving speed must always be adapted to the ambient conditions and load status.
Three-wheel vehicles are less stable than four-wheel vehicles, therefore: avoid sudden steering movements

when driving at higher speeds, taking corners at too high a speed could cause the vehicle to tip.

Only use the vehicles on level surfaces, never on gradients.

Drive up and down inclines in straight lines.

When driving up, down or across slopes, avoid turning corners suddenly or in jerks. There is a risk of tipping when in an inclined position!

- Do not drive the vehicle on slopes with a gradient steeper than the limit gradient indicated on the vehicle.
- The approved gross total weight and permissible axle loads must never be exceeded. Check the fill level of the sweepings container at frequent intervals.
- Before raising or lowering the sweepings container, ensure that there are no persons, animals or items in the working area.
- Risk of crushing and shearing. Before raising or lowering the sweepings container, ensure that there is a sufficient safety clearance.
- The sweepings container may only be raised in the direct vicinity of the waste container.

Only empty the sweepings container on level, solid ground.

- Never sweep when the sweepings container is in a raised position.
- Pay attention to any persons in the vicinity when emptying the sweepings container.
- The filter may only be shaken when the sweepings container has been closed.
- Pay attention to hot parts, e.g. cooling water, exhaust manifold, etc.
- Never exceed the max. load capacity of the container!
- The vehicle may only be driven at creeping speed when the sweepings container has been raised. Avoid any sudden steering movements or braking.
- If you smell exhaust fumes, switch off the engine immediately and locate the cause. Check the exhaust system at regular intervals.
- When the vehicle is running at creeping speed, check the zero point adjustment of the accelerator.
- When driving down a slope, decelerate the vehicle with the brake; in an emergency, switch the vehicle off by removing the ignition key.

Safety Information

- Before starting to drive, the seat console must be locked by means of the rollover bar (only with proof roof option).
 - Do not use the vehicle in areas where the driver is at risk of being hit by falling objects (e.g. warehouses) without a protective roof structure (refer to proof roof option). Contact the trade association responsible for you as to whether obligations exist in this respect.
- ### 1.4 Maintenance information
- Operating personnel must complete the necessary daily and weekly maintenance work. All other maintenance work must be completed at your nearest Hako service center.
 - The maintenance work and maintenance intervals prescribed in the operating manual must be adhered to.
 - Allow the engine to cool down before starting cleaning and maintenance work. Hot surfaces represent a risk of burns!
 - Pay attention to any rotating parts before starting cleaning and maintenance work. They represent a risk of crushing!
 - Suitable tools must be used for cleaning and maintenance work.
 - The vehicle must be inspected by a recognized technical expert in respect of operational safety, within the terms of the applicable accident prevention laws, at reasonable intervals (we recommend at least once a year) and following modification or repairs.
 - Spare parts must comply with the minimum technical requirements stipulated by the manufacturer! This is ensured by the use of original spare parts.
 - Only use the rotary brushes and side brushes recommended by the manufacturer (refer to Technical Data). The use of other rotary brushes and side brushes could impair safety.
 - Only use the air and oil filters recommended by the manufacturer (refer to Technical Data). The use of other filters could impair safety.
 - The vehicle must be switched off prior to cleaning or servicing it or to replacing parts.
 - The ignition key must be removed.
 - The sweepings container must be cleaned regularly to prevent the accumulation of bacteria.
 - The vehicle is splashproof (IPX3). It is not permitted to clean the vehicle with a pressure washer or steam blaster.
 - The engine must be switched off when transporting the vehicle.
 - If the Sweepmaster is jacked up with a jack, it must be properly supported.
 - No persons may be on the Sweepmaster when it is jacked or raised.
 - When changing wheels, the vehicle must be additionally secured from rolling away by placing wheel chocks against the wheels.
Always change wheels on level, solid ground, where possible.
 - Do not remove or replace tires or repair one on a rim. Always go to a proper workshop for work on tires and rims because they have specially trained personnel and special safety tools. Never loosen the screws in the two-part rims while the wheel is still mounted on the vehicle and there is air in the tires. Risk of severe injury!
 - Do not carry out any welding, drilling, sawing or grinding work on frame parts. Damaged parts may only be replaced by specialist workshops ap-

Safety Information

- proved by Hako.
- Only use original fuses. Using fuses which are too powerful could damage the electrical installation and lead to fires.
- Always disconnect the negative pole of the battery when working on the electrical installation.
- Never leave the batteries in a discharged state but recharge them as soon as possible.
- Only refill distilled water. When the cells are in good condition, never refill the battery acid.
- To prevent current leaks, always keep the battery clean and dry, protect it from soiling by metallic dust, for example.
- Battery acid is very corrosive (keep out of reach of children). Wear protective goggles when controlling the acid level. In the event of acid splashing in the eyes, rinse them with water for approx. 15 minutes and seek medical attention immediately. Always wear appropriate protective clothing when handling the battery (e.g. protective gloves, -finger stalls). Never use an open flame (risk of explosion).
- When installing or removing the battery or changing it, there is a risk of crushing and shearing.
- Any fluids (fuel, hydraulic oil) escaping under high pressure can penetrate the skin and cause severe injuries. Seek medical attention immediately in order to prevent the risk of infection. Take care when draining hot oil - risk of burns.
- Subject the brake system to a thorough inspection regularly! Adjustments and repairs to the brake system may only be completed by specialist workshops approved by Hako or recognized brake service workshops.
- Subject the hydraulic system to a thorough inspection regularly! Adjustment and repair work on the hydraulic system may only be performed in specialist Hako workshops.
- Check hydraulic lines and hoses regularly for signs of damage and leaks. Replace damaged lines and hoses immediately.
- Check the exhaust system at regular intervals.

1.5 Particular risks

Safety equipment

- Never operate the Sweepmaster without effective safety equipment (this includes the side door lock)!

Refueling

- Take the utmost care when handling fuel - increased risk of fire! Never fill fuel in the vicinity of naked flames or ignitable sparks! Do not smoke when filling fuel! Switch off the engine, remove the ignition key and apply the parking brake before filling fuel. Never fill fuel in closed rooms! Clear up spilled fuel immediately!

Electronics

- Only use original fuses with the prescribed amperage.
- In the case of defects in the electrical installation, switch the vehicle off immediately and clear the fault.
- Work on the electrical equipment may only be carried out by electricians who have received the necessary training and in accordance with the electrical engineering regulations.
- The vehicle's electrical equipment must be inspected/checked at regular intervals. Defects, such as loose

Safety Information

connections and cable damage, must be rectified immediately.

- Observe the information in the operating manual provided by the battery manufacturer.
- Never lay any metallic objects or tools on batteries - risk of short circuit!
- Ensure sufficient ventilation in the charging area when charging the batteries – risk of explosion!
Open the seat cover during the charging process.

1.6 Environmental protection

- A certain factual expertise is required in order to use substances which could represent a risk to health and the environment.
- Always observe legal regulations and local directives when disposing of cleaning agents, refer to the Water Resources Act.
- Used batteries with the recycling symbol contain reusable commodities. In accordance with symbol with the crossed out garbage bin, these batteries must not be disposed of in domestic waste. The return and recycling of old batteries must be

agreed on with your authorized Hako dealer in accordance with the Battery Law § 6 and § 8 (BattG).

Safety Information

1.7 Labels on the vehicle

The following safety and warning labels are attached to the vehicle where easily legible. Missing or illegible labels must be replaced immediately.

Company logo (Fig. 1/1), front and rear



Rating plate (Fig. 1/2)



Vehicle identification number (Fig. 1/3)

6464xxxxxxxx

Machine model (Fig. 1/4)

Sweepmaster P1500 RH
Sweepmaster D1500 RH

Parking brake (Fig. 1/5)



Read and observe the operating manual (Fig. 1/6)



High-pressure washer/Steam cleaner (Fig. 1/7)



Sound power / Gradient (Fig. 1/8)

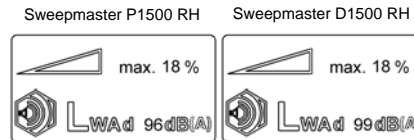

Pressing force (Fig. 1/9)



Front skirt (Fig. 1/10)



Fuses (Fig. 1/11)

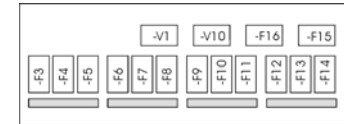

Risk of crushing by sweepings container (Fig. 1/12)



Safety Information

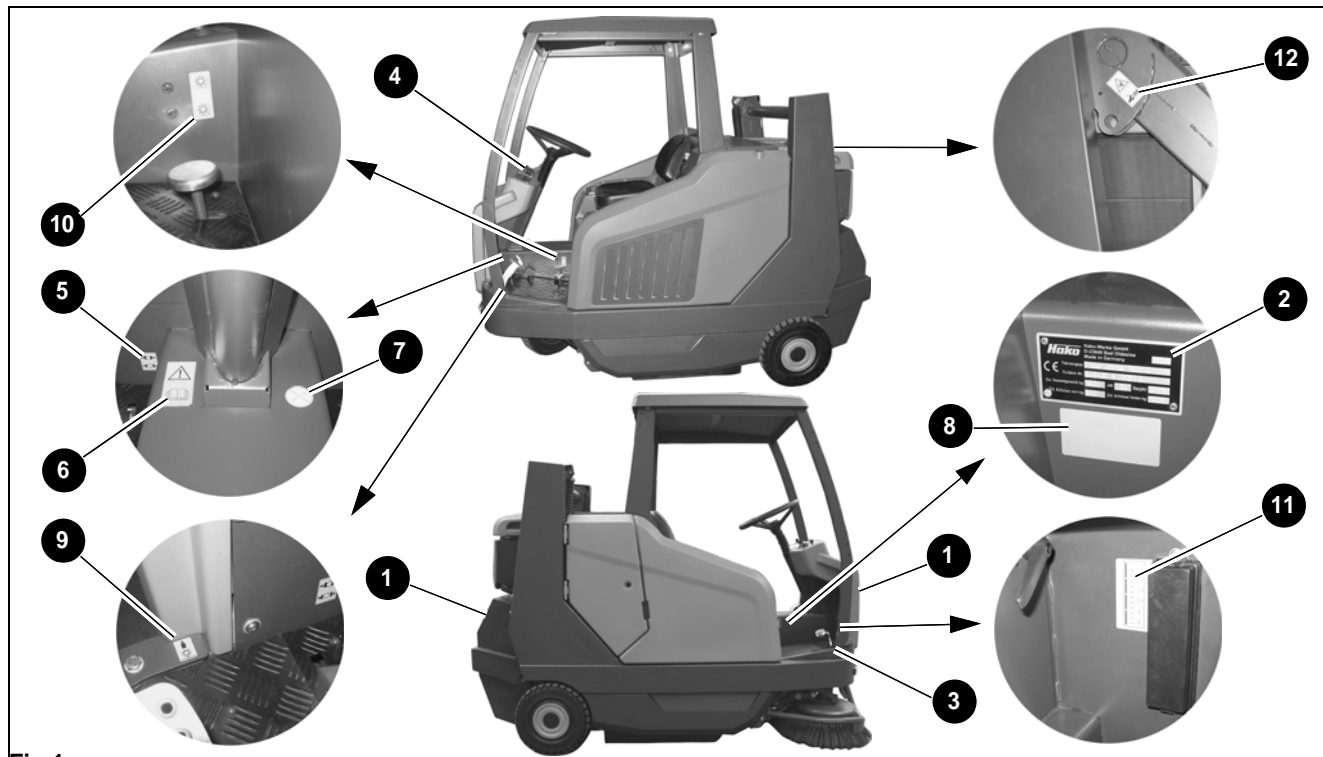

Fig.1

Safety Information

Brush wear compensation
(Fig. 2/1)



Hot surface on exhaust manifold
(Fig. 2/4)



Keep clear of sweepings container
(Fig. 2/2)



Risk of crushing in fan (Fig. 2/5)



Risk of crushing by sweepings container
(Fig. 2/6)



Hydraulic oil (Fig. 2/3)



Safety Information

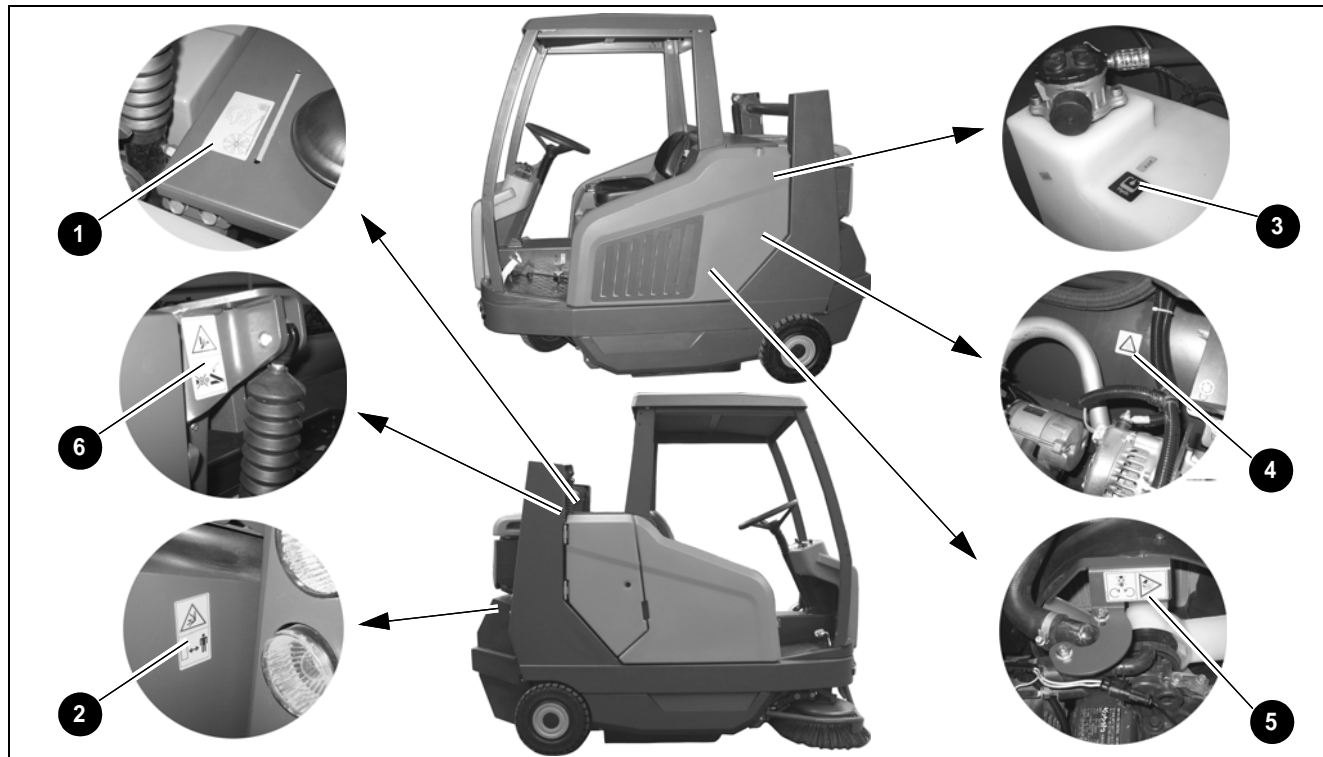

Fig.2

2 Operation

2.1 Instruction

Instructions to operators are required before putting the machine into service. Only technicians from your local authorized Hako dealer are allowed to provide initial instruction on the machine. The manufacturing plant will notify the dealer immediately after delivering the vehicle and the dealer will contact you to arrange a date.

Operation

2.2 Prior to starting up



Read the operating instructions concerning the vehicle provided in Chapter 1, observed them and familiarize yourself with the operating procedures.

1. Check the parking space for signs of leaks. Hoses, lines and tanks must show no signs of leaks or damage.
2. Check the fuel supply in the transparent tubing (Fig. 3/1), refill if necessary.
3. Check the engine oil level with the dipstick (Fig. 3/2), refill if necessary.
4. Check the level of coolant in the radiator (Fig. 3/3), refill if necessary.
5. Check the hydraulic oil level in the hydraulic tank (Fig. 3/4), refill if necessary.
6. Check the adjustment of the driver's seat (Fig. 3/5).
7. Check the steering wheel adjustment, readjust with the lever (Fig. 3/6), if necessary.
8. Closed the locking mechanism, see chapter 5.4.1 (only with weather-proof roof option)

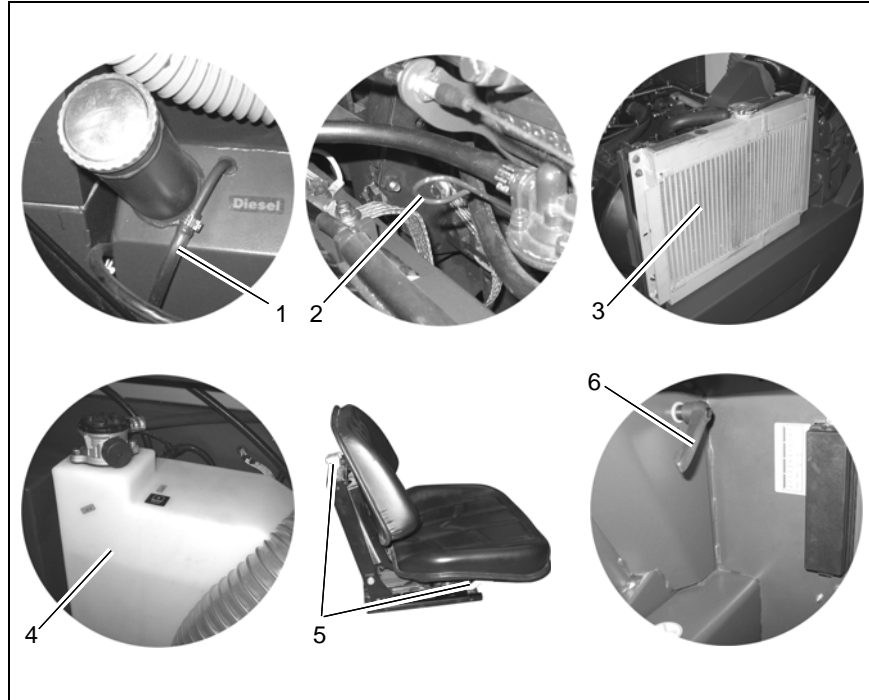

Fig.3

2.3 Starting the engine



Pay attention to the following information before starting the vehicle:

- For safety reasons, the driver's seat is equipped with a seat contact switch. The engine can only be started when the operator is sitting on the driver's seat. The function of the seat contact switch must not be bypassed.
- The seat contact switch is monitored electronically. Any attempt at manipulation can lead to the vehicle being automatically locked against use.
- The Sweepmaster may only be used in ambient temperatures up to 40°C. It should not be started at temperatures <-15°C. At extremely low temperatures, the hydraulic system requires a few minutes until it reaches operating temperature and can provide its full power output. Full loads should only be applied to the units on reaching operating temperature.
- If the start procedure must be repeated or the engine stalls, it can only be restarted after the ignition has been switched off. A restart blocking system in the ignition lock prevents restarting when the engine is running.
- Attempt to start continuously for max. 20 seconds, allow a short pause in between each start procedure to save the batteries.
- The start procedure must be completed after approx. 1 minute. If the ignition remains on too long without the engine switching on, the start procedure is interrupted. A service code appears on the operating hour counter. Make another attempt to start the engine after switching the ignition off.
- If the vehicle is overloaded, the engine speed drops and the engine is switched off.
- The accelerator must be in the neutral position. The position of the accelerator pedal is monitored.

Operation

Procedure to start the diesel engine (only for Sweepmaster D):

1. The accelerators (Fig. 4/1) must be in their neutral setting.
2. The vehicle's parking brake must be applied (Fig. 4/2).
3. Set the engine speed switch (Fig. 4/3) to working speed (hare).
4. Turn the ignition key clockwise to the preheating device icon (Fig. 4/4). Allow to preheat until the control lamp (Fig. 4/A) goes out (max. 20 seconds).
 - The operating hour counter (Fig. 4/ C) displays the software version, possibly the last diagnostic code and the operating hours in succession. The control lamps for the engine oil pressure (Fig. 4/B) and charge control (Fig. 4/D) light up.
5. Turn the ignition key further to START and start the engine.
 - The control lamps for engine oil pressure and charge control must go out after the start procedure.

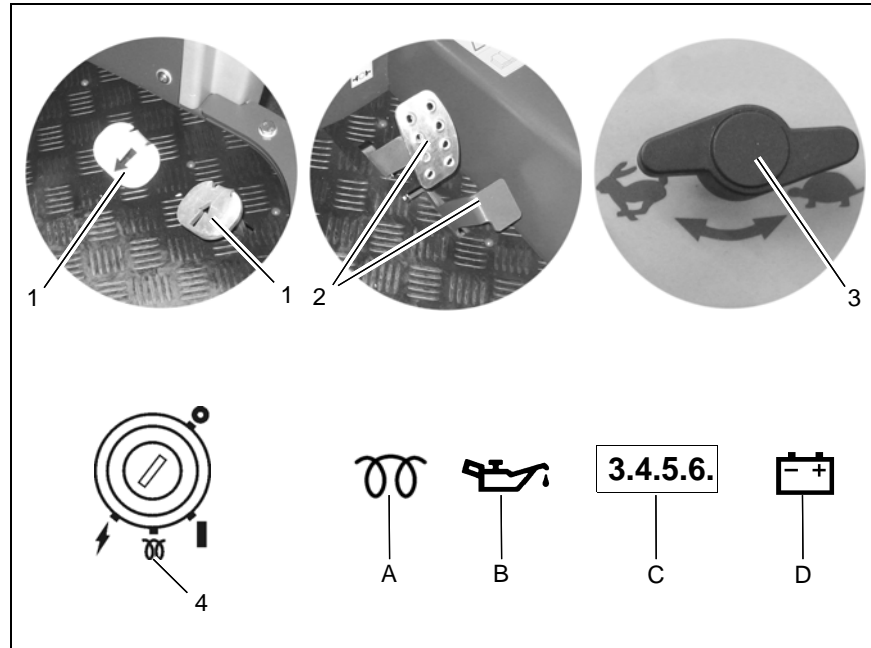

Fig.4

Operation

Procedure to start the petrol engine (only for Sweepmaster V):

1. The accelerators (Fig. 5/1) must be in their neutral setting.
2. The vehicle's parking brake must be applied (Fig. 5/2).
3. Actuate choke (with cold engine only).
4. Set the engine speed switch (Fig. 5/3) to working speed (hare).
5. Turn the ignition key clockwise to the ignition icon (Fig. 5/4).
 - The operating hour counter (Fig. 5/B) displays the software version, possibly the last diagnostic code and the operating hours in succession. The control lamps for the engine oil pressure (Fig. 5/A) and charge control (Fig. 5/C).
6. Turn the ignition key further to START and start the engine.
 - The control lamps for engine oil pressure and charge control must go out after the start procedure.

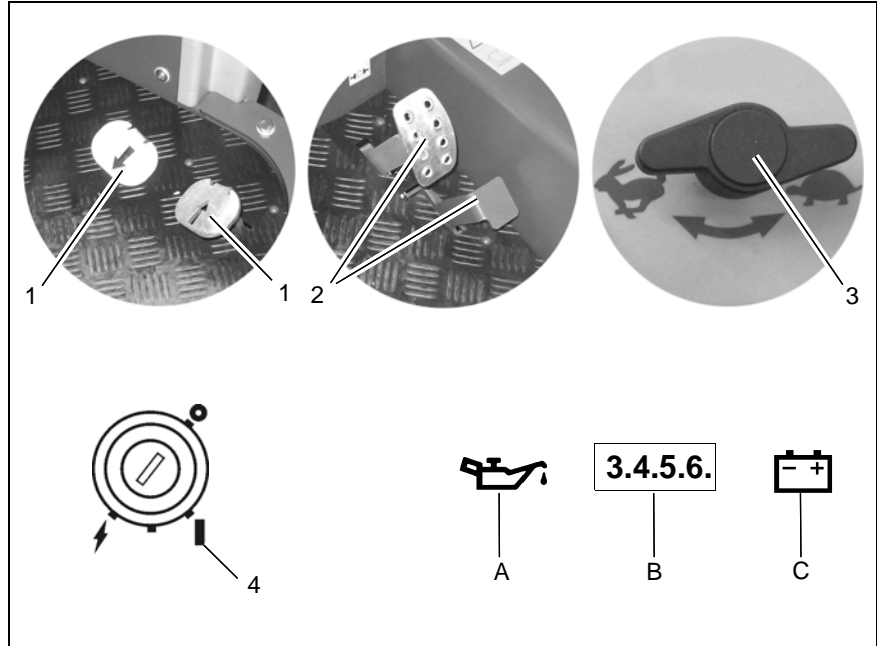

Fig.5

Operation

2.4 Stopping and switching off the vehicle

1. Move the accelerator (Fig. 6/1) slowly to its zero setting. The vehicle slows down to a stop.
2. Apply the parking brake (Fig. 6/2) to its end position and lock in place.
3. Switch off the sweeping functions with the button (Fig. 6/A). The filter agitating system is activated.
4. Switch off the engine with the ignition key (Fig. 6/3).



Remove the ignition key when getting off the vehicle to prevent unauthorized use.

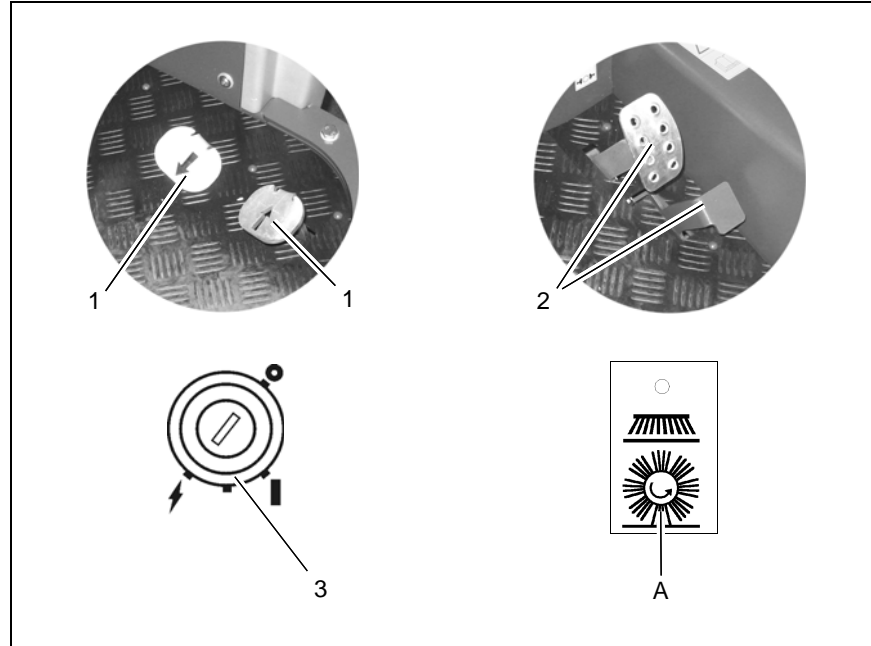

Fig.6

Operation

2.5 Sweeping operation

1. Check the vehicle, refer to Section 2.2.
2. Start the vehicle, refer to Section 2.3.
3. Set the engine speed switch (Fig. 7/ 1) to working speed (Hare).
4. Switch on the sweeping function with the button (Fig. 7/A). The rotary brush, side brush and suction turbine are activated.
5. In the case of damp waste, switch the suction turbine off with the button (Fig. 7/B).
6. Release the parking brake (Fig. 7/2) to its end position.
7. Slowly press the accelerator (Fig. 7/ 3) until the required driving speed is reached.
8. It is recommended to clean the filter regularly. To do this, actuate the button (Fig. 7/C).
9. Check the contents of the sweepings container regularly. Empty the sweepings container as necessary.

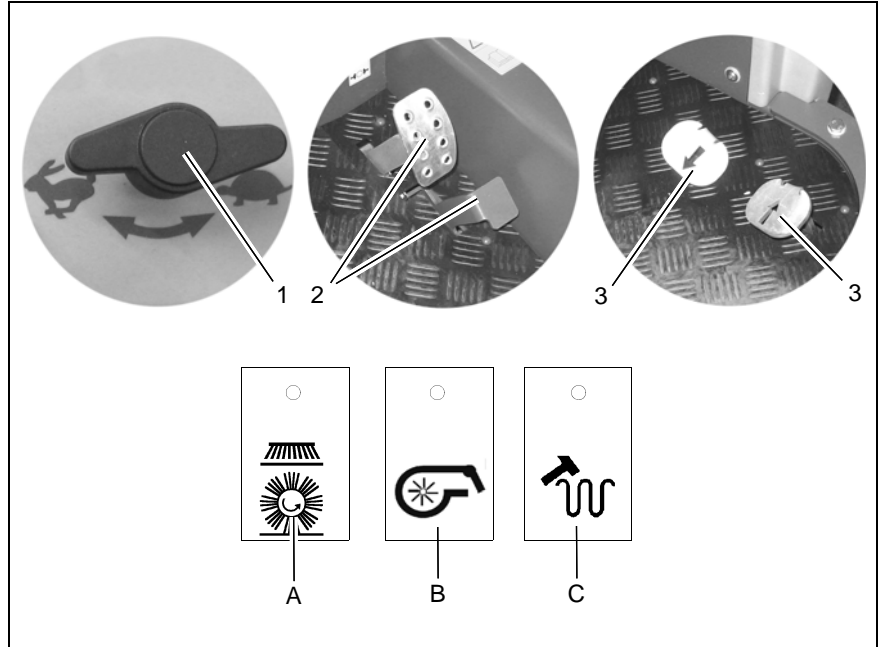

Fig.7

Operation

2.5.1 Emptying the sweepings container



Observe the following safety information before emptying:

- Driving the vehicle with the sweepings container raised reduces the vehicle's stability. Therefore, only raise the sweepings container immediately prior to emptying it.
- Only raise the sweepings container when the vehicle is on a horizontal surface.
- Before raising the sweepings container, the operator must have ensured that there are no persons or objects behind or beside the vehicle.
- The vehicle may only be driven slowly when the sweepings container is raised.
- It is forbidden for anyone to move into the danger area. Risk of crushing and shearing!
- Before raising or lowering the sweepings container, ensure that there is a sufficient safety clearance.
- The sweeping container can only be tipped when the container has been raised beyond a minimum height.

Operation

Procedure to empty the sweepings container:

The sweepings container must be emptied at regular intervals. Ensure the maximum fill weight is never exceeded.

1. Switch off the sweeping functions with the button (Fig. 8/F). The filter agitating system is activated.
2. Agitate the filter too, if necessary. To do this, actuate the button (Fig. 8/E).
3. Raise the sweepings container. To do this, press and hold the button (Fig. 8/A) until the container is lifted to the height required.
4. Empty the sweepings container. To do this, press and hold the button (Fig. 8/B) until the sweepings container is pivoted vertical.
5. Pivot the sweepings container back again by pressing the button (Fig. 8/C).
6. Drive the Sweepmaster away from the garbage container and lower the sweepings container to its end position using the button (Fig. 8/D). The end position is detected and the sweepings container is automatically pivoted back, if necessary.

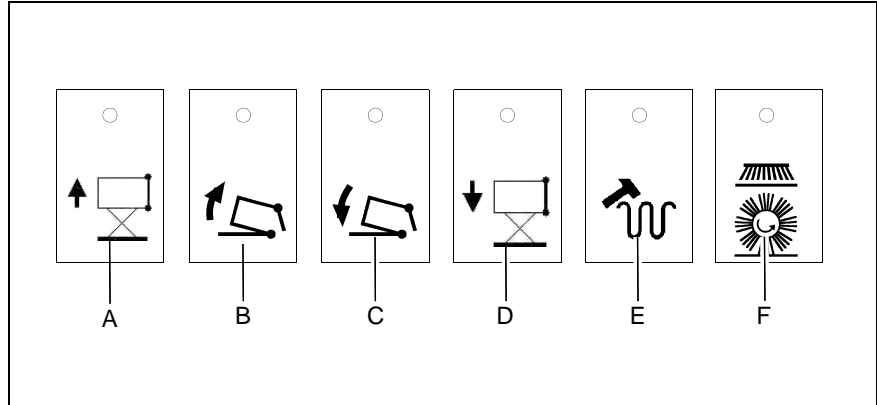

Fig.8

Operation

2.6 Function faults



The following applies when locating and clearing faults: Switch the vehicle off and remove the ignition key!

2.6.1 Service code table

In the case of system errors, a four-digit error code appears in the left-hand operating panel in addition to the service indicator (wrench symbol). The dots in the service code flash.

Clear the fault or note down the service code and inform your authorized Hako dealer. When the cause has been cleared, the error must be acknowledged by switching the ignition key OFF/ON.

Error code	Cause	Solution
3.1.6.A.	Safety fuse F3 defective (hydraulic valves, fuel supply, starter release)	Change fuse, ignition key OFF/ON
3.1.6.C.	Safety fuse F4 defective (belt tension clutch dust vacuum)	Change fuse, ignition key OFF/ON
3.1.6.E.	Safety fuse F2 defective (agitating motor)	Change fuse, ignition key OFF/ON
2.2.6.3.	Hydraulic valve for rotary brush "Raise/Lower/ON/OFF" (overloaded, defective or not connected)	Check hydraulic valve Y2/Y3, ignition key OFF/ON and restart engine
2.3.6.6.	Hydraulic valve for right-hand side brush "Lower/ON" (overloaded, defective or not connected)	Check hydraulic valve Y5, ignition key OFF/ON and restart engine
2.3.6.7.	Hydraulic valve for right-hand side brush "Raise/OFF" (overloaded, defective or not connected)	Check hydraulic valve Y4, ignition key OFF/ON and restart engine
2.4.6.1.	Lifting element for belt tension clutch, dust vacuum (overloaded, defective or not connected)	Check lifting element M5, ignition key OFF/ON and restart engine
2.5.6.1.	Agitating motor overloaded or not connected	Check agitating motor, ignition key OFF/ON and restart engine

Operation

Error code	Cause	Solution
2.6.6.1.	Turn hydraulic valve for sweepings container (overloaded, defective or not connected)	Check hydraulic valve Y7/Y6, ignition key OFF/ON and restart engine
2.6.6.2.	Hydraulic valve for sweepings container "Raise/Lower" (overloaded, defective or not connected)	Check hydraulic valve Y9/Y8, ignition key OFF/ON and restart engine
3.4.5.6.	If the vehicle is overloaded, the engine speed drops and the engine is switched off.	Ignition key OFF/ON and restart engine
3.6.6.1.	Fuel valve (with gasoline/LPG) (overloaded, defective or not connected) Stop engine signal (with diesel) (overloaded, defective or not connected)	With gasoline/LPG: Check fuel valve, ignition key OFF/ON and restart engine With diesel: Check control relay K10, check actuator Y1 (engine stop), ignition key OFF/ON and restart engine
3.6.6.2.	Starter release is overloaded, defective or not connected	Ignition key OFF/ON and restart engine
3.6.6.3.	Accelerator position detector is defective or has been manipulated	Move the accelerator and set to the neutral position, ignition key OFF/ON and restart the engine
3.6.6.4.	Timeout seat contact, i.e. no driver has been detected on the seat for a longer period. Seat contact has been manipulated or defective	Actuate the seat contact, ignition key OFF/ON and restart the engine

Operation

2.7 Transporting

In order to transport the vehicle on a loading space, apply the parking brake and also secure the vehicle using straps at both front lashing points (Fig. 9/1) and the two rear lashing points (Fig. 9/2) which are located in the wheel case.

2.8 Towing the vehicle

When the drive motor has stopped, the front wheel is locked. To tow the vehicle, the bypass valve (Fig. 9/3) on the hydraulic pump must be opened. The bypass valve is opened by turning approx. 1 1/2 to 2 revolutions.

Towing distance: Max. 500 m to move the machine from the hazard area.

Towing speed: Max. 5 kph. The two front lashing points (Fig. 9/1) can be used as towing lugs.

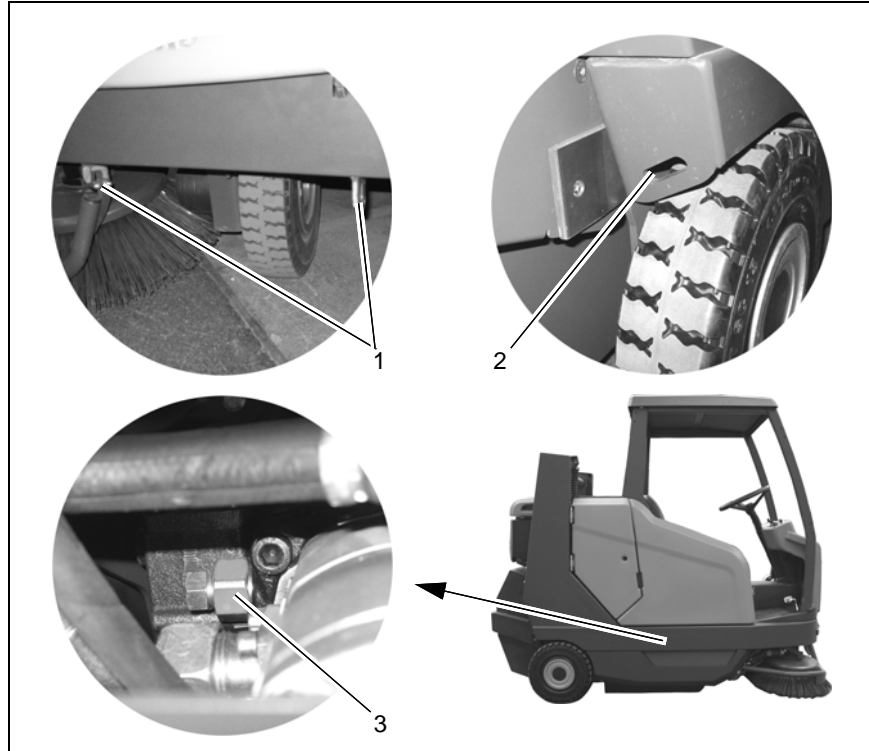

Fig.9

3 Operation

3.1 Method of operation

General information

The Sweepmaster is a sweeping vehicle exclusively designed for sweeping up dry and wet waste from floor surfaces as in production plants, warehouses, car parks and pedestrian precincts.

Sweeping

The side brush (Fig. 10/1) sweeps the dirt directly into the pick-up path (Fig. 10/2) of the rotary brush (Fig. 10/2). The rotary brush sweeps the dirt overhead (Fig. 10/3) into the sweeping container (Fig. 10/4). The particulate matter (Fig. 10/5) swirled up is vacuumed up by the suction turbine (Fig. 10/7) and forced against the filter (Fig. 10/6) which filters it. Dirt disposal is realized via hydraulic lift-up (Fig. 10/8).



Fig.10

Operation

3.2 Operating elements

3.2.1 Operating panel A

- 1 Control lamp for preheating
- 2 Control lamp for engine oil pressure
- 3 Control lamp for parking brake
- 4 Control lamp for service indicator
- 5 Operating hour counter / Service code
- 6 Control lamp for fuel reserves
- 7 Control lamp for coolant temperature
- 8 Button to raise the sweepings container
- 9 Button to pivot the sweepings container for emptying
- 10 Button to pivot the sweepings container back
- 11 Button to lower the sweepings container
- 12 Button for the filter agitation system
- 13 Button for the suction turbine
- 14 Button for the rotary brush
- 15 Button for the rotary brush and side brush

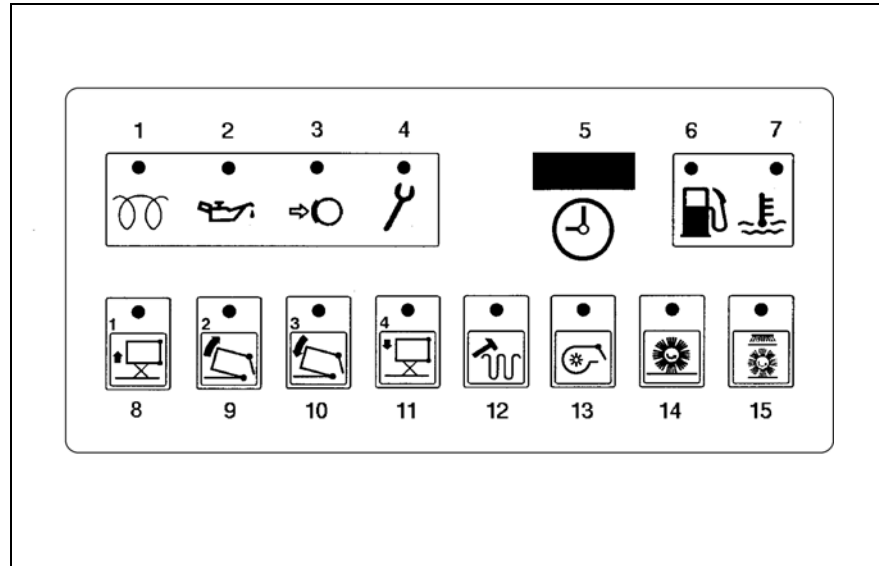
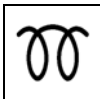

Fig.11

Operation



Control lamp for preheating (Fig. 11/1) (only Sweepmaster D)

It lights up for max. 20 seconds after actuating the ignition starter switch. The engine can be switched on when the control lamp goes out.



Control lamp for engine oil pressure (Fig. 11/2)

It lights up if the oil pressure is too low (e.g. insufficient engine oil). Stop the vehicle immediately and fill engine oil. If the control lamp does not go out after refilling, contact your authorized Hako service center.



Control lamp for brake (Fig. 11/3)

It lights up when the brake is actuated. The control lamp goes out when the brake is released.



Control lamp for service indicator (Fig. 11/4)

It lights up when an error has occurred in the system. In addition to the Service indicator, a four-digit service code appears in the operating hour counter display. The dots in the service code flash. Clear the fault or note down the service code and inform your authorized Hako dealer. After clearing the fault, acknowledge it by turning the ignition key OFF/ON.

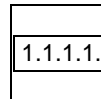

Operating hour counter/Service code (Fig. 11/5)

The software version, last service code and current operating hour status appear in the operating hour counter display briefly after switching the ignition on. If the display flashes, it means the driver's seat is not occupied. An overview of possible errors is provided in the service code table in Section 2.6.



Control lamp for fuel reserves (Fig. 11/6)

It lights up as soon as only approx. 3 liters of fuel remain in the tank. A single acoustic signal is also issued.

Operation



Control lamp for coolant temperature (Fig. 11/7)

It lights up as soon as the coolant has become too warm. Switch the engine off immediately and locate the cause.

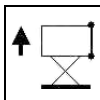

Button to raise sweepings container (Fig. 11/8)

It serves to raise the sweepings container. To raise the container, press the button until it is at the required height. The control lamp in the button lights up. If the button to raise the container is pressed during sweeping operation, the sweeping function is deactivated.

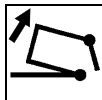

Button to pivot the sweepings container for emptying (Fig. 11/9)

It serves to pivot the sweepings container to a vertical position for emptying. The control lamp in the button lights up. The sweeping container can only be tipped when the container has been raised beyond a minimum height.



Button to pivot the sweepings container back (Fig. 11/10)

It serves to pivot the sweepings container horizontal because it can only be lowered when in a horizontal position. The control lamp in the button lights up.

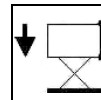

Button to lower the sweepings container (Fig. 11/11)

It serves to lower the sweepings container. To lower the container, press the button as long as necessary until it is against the frame. The control lamp in the button lights up. The sweepings container pivots in automatically, if necessary.



Button for filter agitation system (Fig. 11/12)

On actuating the switch, the agitating device is switched on and the filter system cleaned. The agitation process takes approx. 15 second. The control lamp in the button lights up. During the agitation process, the suction turbine is automatically deactivated. If the control lamp in the button starts to flash (single acoustic warning), the filter is extremely soiled and must be agitated clean.

Operation



Button for suction turbine (Fig. 11/13)

It serves to switch the suction turbine on and off. When the suction turbine is switched on, the control lamp in the button lights up. If the control lamp flashes, the suction turbine is in the switching on or off phase.



Switch the suction turbine off in the case of wet waste.



Button for rotary brush (Fig. 11/14)

It serves to switch the rotary brush on and off. When the rotary brush is switched on, the control lamp in the button lights up.



Button for sweeping functions (Fig. 11/15)

It serves to switch the sweeping operations on and off. The rotary brush, side brush and suction turbine are switched on and off.



Sweeping operation can only be used at working speed (here).

If the sweeping operation is switched off, the filter agitation system is automatically activated.

Operation

3.2.2 Operating panel B

- 1 Ignition starter switch
- 2 Load control lamp
- 3 Switch for engine speed
- 4 Horn switch
- 5 Switch for parking light/driving lights (option)
- 6 Switch for hazard lights (option)
- 7 Switch for flashing beacon (option)
- 8 Switch for drive direction indicator with control lamp (option)
- 9 Choke (Sweepmaster V only)
- 10 Switch for Dual Fuel (option)

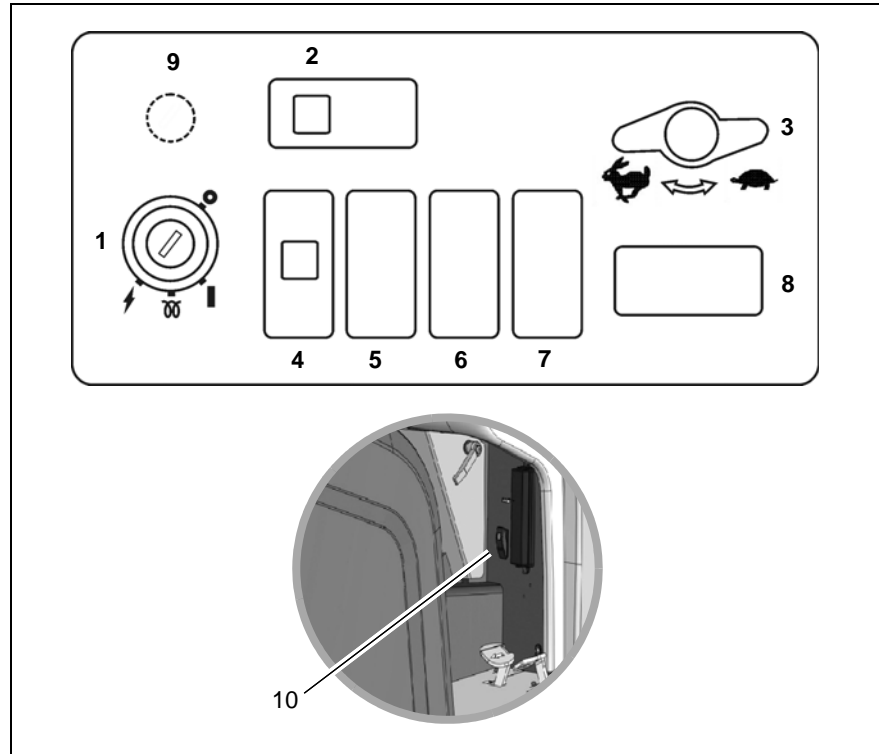
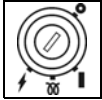

Fig.12

Operation



Ignition starter switch (Fig. 12/1)

It serves for preheating (Hako Jonas 1500 D only), to switch the engine on/off and lock the vehicle against unauthorized use.



To start the engine, both accelerators must be their neutral position.

0 = engine and electrical system switched off.

1 = Ignition ON

2 = Preheat until the control lamp goes out (only Hako Jonas 1500 D)

3 = Start.



For reasons of safety, the Sweepmaster is equipped with a seat contact switch. The engine can only be started when the operator is sitting on the driver's seat. If the seat contact is interrupted while the engine is running, the engine is switched off and the operating hour counter flashes.

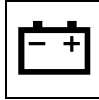

Load control lamp (Fig. 12/2)

It lights up as soon as the ignition switch is actuated and goes out when the engine starts up.



Switch for engine speed (Fig. 12/3)

The switch serves to set the engine speed.

- Right-hand position (tortoise): Idling speed to switch the engine on and off
- Left-hand position (hare): Working speed for traction drive and sweeping operation

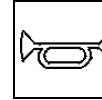

Switch for horn (Fig. 12/4)

An acoustic signal is issued on actuating the switch.

Choke (Fig. 12/9) (Sweepmaster V only)

To actuate the choke flap (cold start aid).

Operation

3.2.3 Operating elements on the machine

Accelerators

They serve for driving forward and in reverse and simultaneously control the speed. If the pedal is released, it automatically returns to its zero position and the vehicle comes to a stop.

Accelerator (Fig. 13/1): Reverse drive
Accelerator (Fig. 13/2): Forward drive

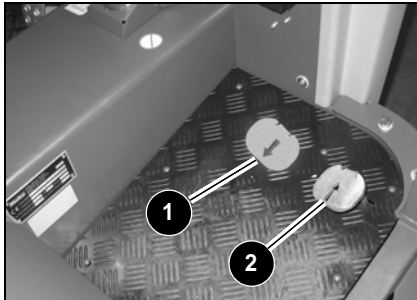

Fig.13

Service brake and parking brake

The service brake (Fig. 14/1) actuates the mechanical drum brakes which act on the two rear wheels. Before getting off the vehicle, apply the parking brake and lock it with the lever (Fig. 14/2). After actuating the brake pedal again, the lock is released.

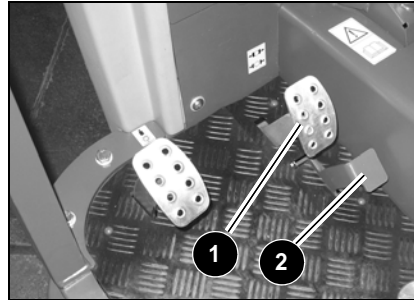

Fig.14

Pedal for rotary brush pressure

The pedal (Fig. 15/1) serves to increase the rotary brush pressure applied on the ground while sweeping. After releasing the pedal, the rotary brush moves back to its initial position.



Fig.15

Operation

Pedal for front skirt

The pedal (Fig. 17/1) is used to raise the front skirt when sweeping large debris.

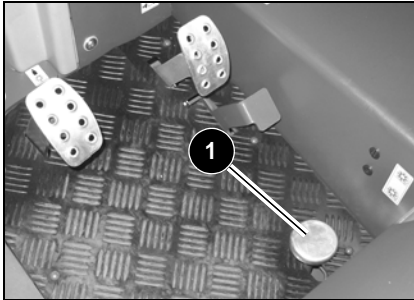

Fig.16

Crank for setting the sweeping pattern

The crank (Fig. 17/1) is used to set the sweeping pattern of the rotary brush. Refer to Chapter "Maintenance and Service" for information on setting the sweeping pattern.

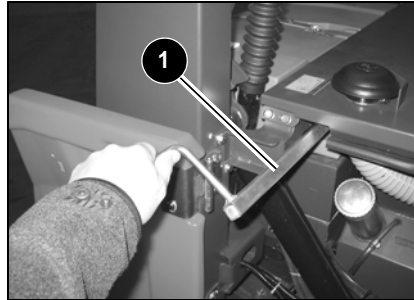

Fig.17

Locking the seat console

For reasons of safety, the seat console is equipped with a lock (Fig. 18/1) (only with proof roof option).



Before starting to drive, ensure that the seat console is secured by the lock!

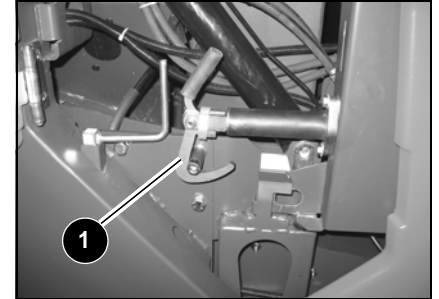

Fig.18

Operation

Checking the sweepings container

The sweepings container is provided with an opening in order to throw in waste collected manually. The fill volume of the sweepings container can be monitored through the opening (Fig. 19/1).

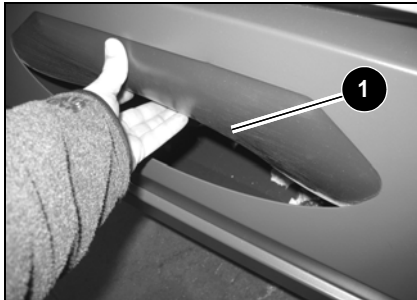

Fig.19

Filter system lock

The filter system is above the sweepings container. The cover of the filter system is secured by the lock (Fig. 20/1). The filter and agitation device is under the cover. Refer to Chapter "Maintenance and Service" for information on cleaning the filter.

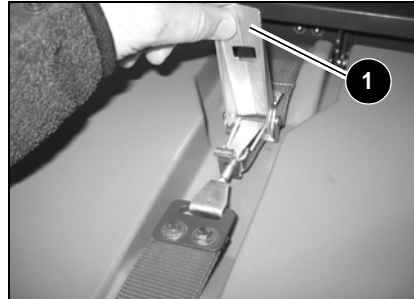

Fig.20

Dual Fuel System (Option)

The vehicle is optionally equipped with a dual fuel system. This means that you can choose whether to use gasoline or liquefied petroleum gas as fuel for the combustion engine.

Switch (Fig. 21/1) to its top position:

- The combustion engine is set to run on gasoline
 - The symbol in the switch is lights up
- Switch (Fig. 21/1) to its bottom position:
- The combustion engine is set to run on liquefied petroleum gas
 - The symbol in the switch is out

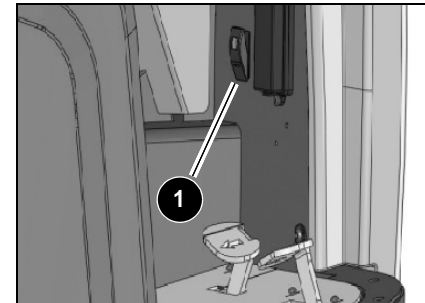

Fig.21

Operation

Driver's seat

The driver's seat (Fig. 22/1) must be adjusted so that the driver is seated comfortably and can reach all the operating elements with ease.

- The seat suspension can be adapted to the driver's weight (50 kg to 120 kg) using the handwheel (A).
- The driver's seat is released by means of the lever (B) and can be adjusted in a longitudinal direction.



For reasons of safety, the Sweepmaster is equipped with a seat contact switch. The engine can only be started when the operator is sitting on the driver's seat. If the seat contact is interrupted while the engine is running, the engine is switched off and the operating hour counter flashes.

Any attempt to manipulate the seat contact switch can lead to the vehicle being automatically locked against use.



Fig.22

Operation

Cab (optional)

Swinging the cab up

The cab can be swung up for maintenance work. Please follow the order described below, since otherwise the cab or machine may be damaged.

1. Switch the engine off and close the cab door.
2. Open the side flap and fit the pump lever onto the hand pump (Fig. 11/1).
3. Set the control lever (Fig. 11/2) on the pump to "raise" (arrow upwards) and pump the cab up with the pump lever until it moves no further.
4. Pull off the pump lever, place it in the holder and close the side flap again.

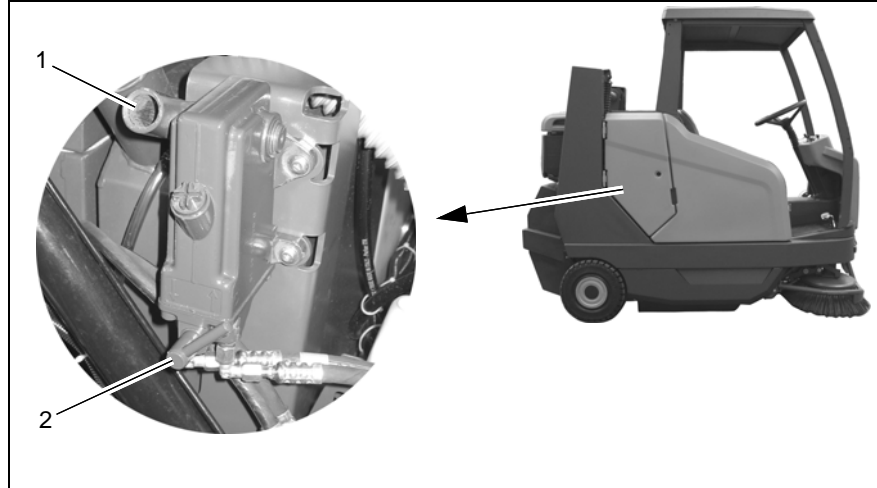

Fig. 23

Operation

Lowering the cab

1. Switch the engine off and close the cab door.
2. Open the side flap and fit the pump lever onto the hand pump (Fig. 12/1).
3. Set the handle (Fig. 12/2) on the pump to "LOWER" (arrow downwards) and pump the cab down with the pump lever until it moves no further.
4. Pull off the pump lever, place it in the holder and close the side flap again.

Switch for wiper

The wiper is switched on and off with the switch (Fig. 12/3). The wiper switches off in the end position.

Opening the rear window

Unlock the rear window with the lever (Fig. 12/4) and set it in the required position.

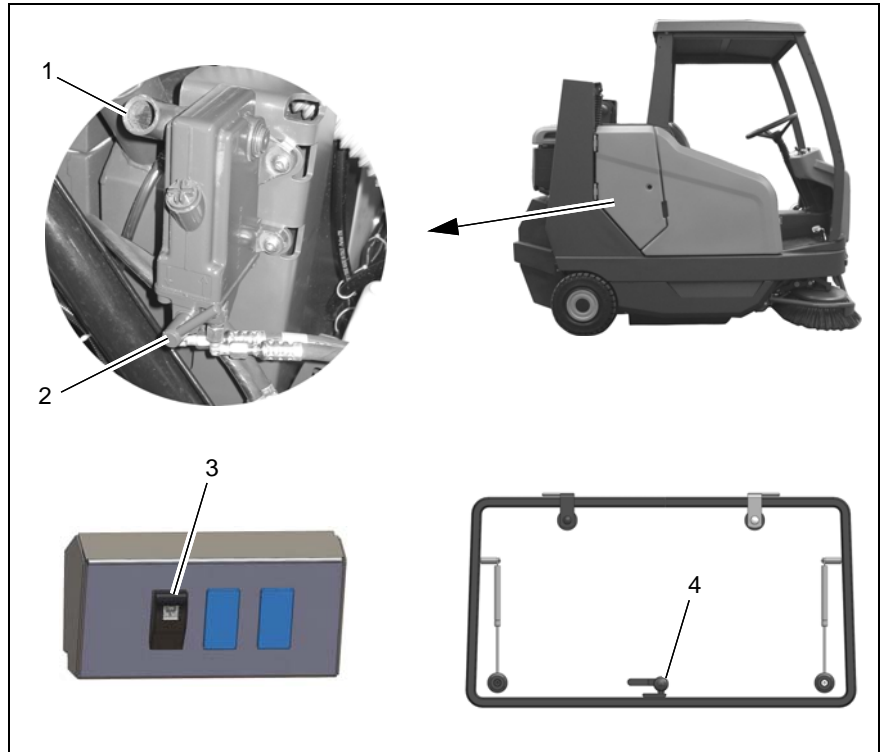

Fig. 24

Operation

Cab heating (optional)

Heating control knob

The temperature is set with the controller (Fig. 13/1).

Setting warmer: Turn the controller clockwise

Setting colder: Turn the controller counter-clockwise

Switch for heating blower

The heating blower is switched on with the switch (Fig. 13/2).

I = slow stage

II = fast stage

Adjusting the air vents

There is one air vent (Fig. 13/3) each on the right and left at the underside of the roof lining. The nozzles can be turned and the flaps adjusted. When the heating is switched off, the blower can also be used to ventilate the cab.

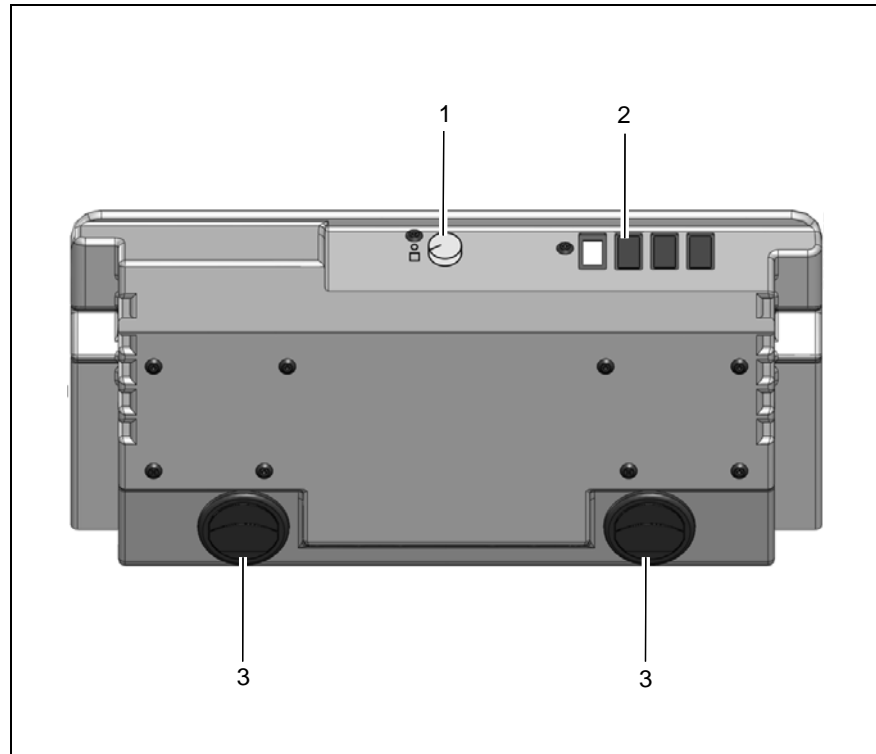

Fig. 25

Technical Data

4 Technical Data

Dimensions and weight		
Length	mm	2256
Width with/without left-hand side brush	mm	1316/1363
Height with/without protective roof	mm	1600/1985
Dead weight	kg	1100
Permissible total weight	kg	1900
Driving and sweeping performance		
Driving speed - forwards	kph	10
Driving speed - reverse	kph	6
Max. sweeping speed	kph	10
Theoretical sweeping performance with/without left-hand side brush	m ² /h	16200/9300
Max. driving gradient	%	18
Rotary brush		
Length / Diameter	mm	920/500
Wear limit	mm	400
Speed	rpm	500 +30
Sweeping pattern	mm	90 +/-10

Technical Data

Sweepings container and filter system		
Sweepings container volume	Liters	250
Filter surface	m ²	7,5
Side brushes		
Diameter	mm	600
Speed	rpm	Max. 95 +/-5
Wheels		
Tyres, front	CSE	4.00-8
Tyres, rear	Air/CSE	4.00-8
Hydraulic system		
Hydraulic oil, e.g. Mobiloil		DTE 15M or DTE 10 Excel
Tank volume	Liters	25
Electrical installation		
Starter battery	V / Ah	12/54
Three-phase generator	V/A	12/40
Protection class against penetration by moisture		IPX3

Technical Data

Diesel engine (Sweepmaster D)		
Manufacturer		Kubota
Type	Diesel	D902
Working process / No. of cylinders		4 stroke / 3
Cubic capacity	cm ³	898
Output at 2700 rpm	kW	14
Idling speed	rpm	1500 +/-50
Working speed	rpm	2700 +/-50
Coolant		Coolelf Auto Supra -37°C
Coolant fill quantity	Liters	Approx. 3
Fuel		Diesel
Fuel tank capacity	Liters	27
Fuel consumption	Liter / h	2.2
Engine oil	Type	15W40
Engine oil fill quantity with filter	Liters	3.70

Technical Data

Gasoline/Petrol engine (Sweepmaster V)		
Manufacturer		Kubota
Type	Gasoline/Petrol	DF752
Working process / No. of cylinders		4 stroke / 3
Cubic capacity	cm ³	740
Output at 2700 rpm	kW	15
Idling speed	rpm	1500 +/-50
Working speed	rpm	2700 +/-50
Coolant		Coolelf Auto Supra -37°C
Coolant fill quantity	Liters	Approx. 3
Fuel		Gasoline/Petrol
Fuel tank capacity	Liters	27
Fuel consumption	Liter / h	3.0
Engine oil	Type	15W40
Engine oil fill quantity with filter	Liters	3.25

Technical Data

Noise emission values		Sweepmaster D1500 RH	Sweepmaster P1500 RH
The sound pressure level (LpA) (at the ear of the operator) measured according to DIN IEC 60335-2-72 under normal working conditions is:	dB (A)	84	80
Measurement inaccuracy (KpA):	dB (A)	2	2
The sound power level (LwAd) measured according to DIN EN 60335-2-72 under normal working conditions is:	dB (A)	99	96
The sound power level (LwAd) measured according to 2000/14/EC under normal working conditions is:	dB (A)	99	96
Vibration values			
The weighted, effective value of the acceleration, established in accordance with ISO 5349-1, to which the upper limbs (hand-arm) are exposed under normal working conditions is:	m/s ²	< 2,5	< 2,5
The weighted, effective value of the acceleration, established in accordance with ISO 2631-1 to which the body (feet-seat surface) is exposed under normal working conditions is:	m/s ²	< 0,5	< 0,5

5 Maintenance and Care

General



Before proceeding to maintenance and care work you are advised to read and comply with the Safety Information chapter!

Compliance with the recommended maintenance works will give you the certitude of always having a reliable machine at disposition.

Daily or weekly maintenance and repair works may be executed by the driver/operator having been trained accordingly. Further Hako system maintenance works have to be executed by qualified personnel only. Please contact your local Hako Service Centre or Hako contract dealer. We cannot be held liable for damages resulting from non-compliance with these instructions. Please indicate the machine's serial number with any enquiry or spare part order, see paragraph 1.7 - Nameplate.

5.1 Hako System Maintenance

The Hako System Maintenance:

- guarantees reliable operability of the Hako machines (preventive maintenance)

• minimizes operating costs, repair costs and maintenance costs

- ensures long service life and operability of the machine

The Hako System Maintenance is structured in separate modules and determines specific technical works to be executed as well as the intervals for such maintenance works. For any specific maintenance type, the replacement parts are determined and listed in spare part kits.

Hako System Maintenance K:

To be performed by the customer in accordance to the maintenance and care instructions contained in the operating instructions (daily or weekly). The driver/operator will be instructed upon delivery of the machine.

Hako system maintenance, one-off:

(After 50 operating hours)

This applies to machines equipped with a combustion engine drive, 1st oil/filter change, filters etc. Must be completed by a skilled technician in an authorized Hako service center.

Hako-System Maintenance I:

(every 125 hours of operation)

To be performed by qualified personnel

of authorised Hako Service Centre in accordance with the machine-specific system maintenance including spare part kit.

Hako-System Maintenance II:

(every 250 hours of operation)

To be performed by qualified personnel of authorised Hako Service Centre in accordance with the machine-specific system maintenance including spare part kit.

Hako-System Maintenance III:

(every 500 hours of operation)

To be performed by qualified personnel of authorised Hako Service Centre in accordance with the machine-specific system maintenance including spare part kit.

Hako-System Maintenance IV/S:

(every 1000 hours of operation safety check)

To be performed by qualified personnel of authorised Hako Service Centre in accordance with the machine-specific system maintenance including spare part kit. Execution of all safety-relevant inspections according to UVV-BGV-TÜV-vDE as prescribed by law.

Maintenance and Care

5.2 Maintenance report

<p>Handover</p> <p>Upgrading Test drive Handover to customer Instruction completed on: at _____ operating hours</p>	<p>Hako System Maintenance 50 operating hours, one-off Workshop Stamp</p> <p>completed on: at _____ operating hours</p>	<p>Hako System Maintenance I 125 operating hours Workshop Stamp</p> <p>completed on: at _____ operating hours</p>	<p>Hako System Maintenance II 250 operating hours Workshop Stamp</p> <p>completed on: at _____ operating hours</p>
<p>Hako System Maintenance I 375 operating hours Workshop Stamp</p> <p>completed on: at _____ operating hours</p>	<p>Hako System Maintenance III 500 operating hours Workshop Stamp</p> <p>completed on: at _____ operating hours</p>	<p>Hako System Maintenance I 625 operating hours Workshop Stamp</p> <p>completed on: at _____ operating hours</p>	<p>Hako System Maintenance II 750 operating hours Workshop Stamp</p> <p>completed on: at _____ operating hours</p>
<p>Hako System Maintenance I 875 operating hours Workshop Stamp</p> <p>completed on: at _____ operating hours</p>	<p>Hako System Maintenance IV/S 1000 operating hours Workshop Stamp</p> <p>completed on: at _____ operating hours</p>	<p>Hako System Maintenance I 1125 operating hours Workshop Stamp</p> <p>completed on: at _____ operating hours</p>	<p>Hako System Maintenance II 1250 operating hours Workshop Stamp</p> <p>completed on: at _____ operating hours</p>

Maintenance and Care

5.3 Maintenance plan Hako system maintenance, customer

The following maintenance work must be completed by the customer at the intervals stipulated.

Activity	Interval
	Daily
Check the fuel supply, refill as necessary	o
Check the sweepings container, empty as necessary	o
Check the engine oil level, refill engine oil as necessary	o
Check the coolant level in the cooling system, refill as necessary	o
Check the hydraulic oil level, refill as necessary	o
Clean the dust discharge valve in the air filter	o
Check the engine and hydraulic system for leaks	o

Maintenance and Care

Hako system maintenance, customer

The following maintenance work must be completed by the customer at the intervals stipulated.

Activity	Interval
	Weekly
Check the radiator cooling ribs, clean as necessary	o
Check the function of the steering	o
Check the the tire pressure	o
Check the air filter, clean the main filter as necessary	o
Check the filter system, clean the filter as necessary	o
Check the function of the agitating device	o
Check the sweepings container seals, replace as necessary	o
Check the side brush for signs of wear, readjust or renew as necessary	o
Check the rotary brush and sealing strips for signs of wear, readjust or renew as necessary	o
Clean the vehicle	o

Maintenance and Care

Hako system maintenance - one-off

The following maintenance work must be completed by an authorized Hako service center.

Activity	Interval
	Every 50 operating hours (one-off)
Change the engine oil	o
Change the engine oil filter	o
Check the engine speed (idling and operating speed)	o
Check the engine and hydraulic system for leaks	o
Change the hydraulic oil filter and refill the necessary oil	o
Check the electrical system	o
Check the function of the parking brake and service brake	o
Check the function of the steering	o
Check the traction drive (forward and reverse drive, neutral position)	o
Check the visual appearance of the vehicle	o
Test drive and function test	o

Maintenance and Care

Hako system maintenance I

The following maintenance work must be completed by an authorized Hako service center.

Activity	Interval
	Every 125 operating hours
Check the exhaust system (risk of poisoning with cab option and defective exhaust sytem)	o
Check the visual appearance of the vehicle	o
Test drive and function test	o

Maintenance and Care

Hako system maintenance II

The following maintenance work must be completed by an authorized Hako service center.

Activity	Interval
	Every 250 operating hours
All maintenance work in accordance with Hako system maintenance I	o
Check the traction drive (forward and reverse drive, neutral position)	o
Check the main filter of the air filter	o
Change the engine oil	o
Change the engine oil filter	o
Check the engine and hydraulic system for leaks	o
Check the engine speed (idling and operating speed)	o
Check the filter system and change the filter	o
Check the tightening torque of the wheel bolts	o
Check the function of the parking brake and service brake	o
Check the hydraulic functions	o
Check the antistatic chain	o
Check the electric system (starter battery, lighting, fuses, relays and control lamps)	o

Maintenance and Care

Hako system maintenance III

The following maintenance work must be completed by an authorized Hako service center.

Activity	Interval
	Every 500 operating hours
All maintenance work in accordance with Hako system maintenance I and II	o
Change the hydraulic oil	o
Change the hydraulic oil filter	o
Change the fuel filter	o

Maintenance and Care

Hako system maintenance IV/S

The following maintenance work must be completed by an authorized Hako service center.

Activity	Interval
	Every 1000 operating hours
All maintenance work in accordance with Hako system maintenance I, II and III	o
Change the air filter safety cartridges	o
Change the coolant in the cooling system	o
Change the brake shoes	o
Change the brake Bowden cables	o

Maintenance and Care

5.4 Seat console

The engine, air filter, radiator, hydraulic system and other components are located under the seat console. The seat console can be pivoted up for cleaning and maintenance purposes.



Allow the engine to cool down before starting any cleaning and maintenance work. Otherwise you could burn yourself on hot surfaces!

5.4.1 Opening the seat console

If the weatherproof roof option is installed, the seat console is equipped with a lock.

1. Park the vehicle on a level surface with the engine at operating temperature. Turn the engine off and allow to cool down. Apply the parking brake.
2. Open the side panel (Fig. 23/1) using a square wrench.
3. Unlock the lock (Fig. 23/2). Pivot the seat console up.



After the seat console has been pivoted back down, it must be locked again.

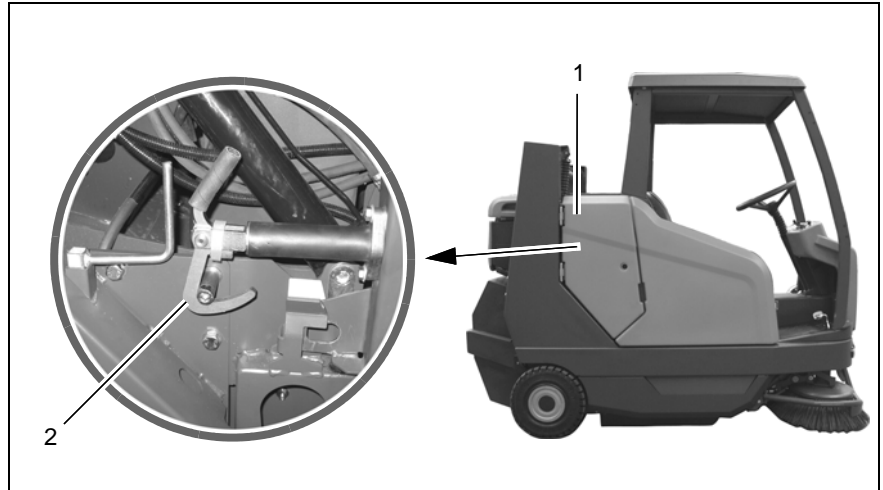

Fig.23

Maintenance and Care

5.5 Engine

The engine is installed under the seat console.



Allow the engine to cool down before starting any cleaning and maintenance work. Otherwise you could burn yourself on hot surfaces!

Pay attention to rotating parts in the vicinity of the fan. Risk of injury!

- 1 Dipstick
- 2 Cap
- 3 Drain plug
- 4 Oilpan
- 5 Oil filter
- 6 Fuel filter
- 7 Fuel filter (diesel only)
- 8 Fuel filter valve
- 9 Vent plugs
- 10 Injection pump
- 11 Fan

Position A = Valve closed
Position B = Valve open

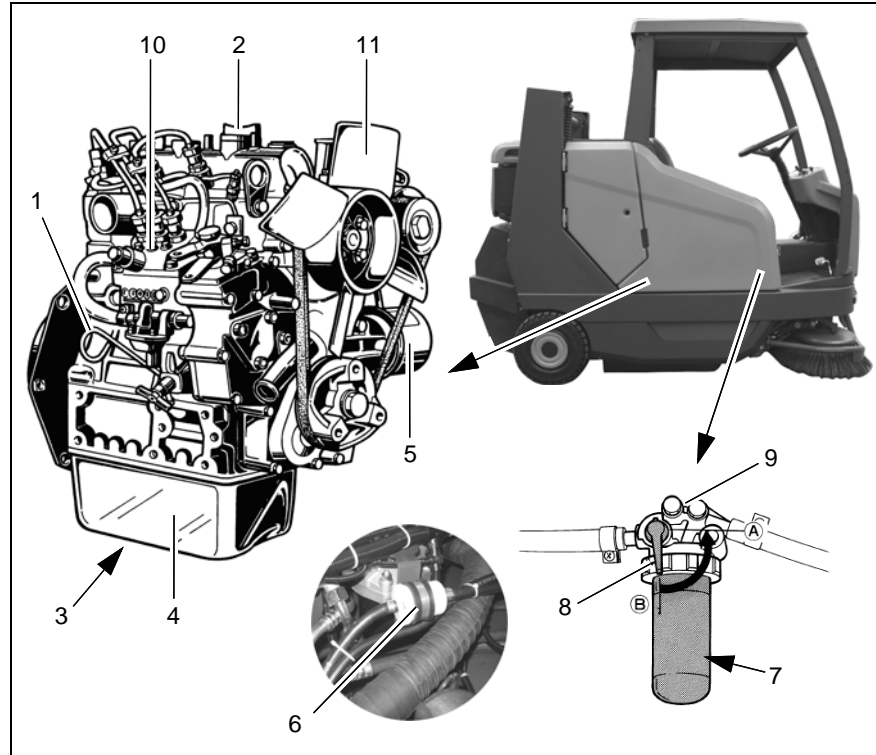

Fig.24

Maintenance and Care

5.5.1 Refilling the engine oil

Check the engine oil level with the oil dipstick (Fig. 23/1) every day. Refill engine oil as necessary or when the engine oil pressure control lamp lights up.



Only use the engine oil prescribed, refer to Technical Data!

1. Open the seat console, refer to Section 5.4.1.
2. Pull the oil dipstick out and wipe it with a clean cloth. Insert the oil dipstick again.
3. Compare the oil level with the marking at the bottom end of the oil dipstick.
4. Remove the cap (Fig. 23/2).
5. Do not pour in too much oil at one time. Allow the oil a few minutes to run into the oilpan. Then measure the oil level again.
6. Replace the cap and oil dipstick.
7. The engine control lamp must go out a few seconds after switching the engine on.

5.5.2 Changing the engine oil and oil filter

Change the engine oil and oil filter (Fig. 23/5) for the first time after 50 operating hours. Subsequently, change the engine oil every 125 operating hours and the oil filter every 250 operating hours.

1. Open the seat console, refer to Section 5.4.
2. Place a suitable collecting vessel under the drain plug (Fig. 23/3) of the oilpan (Fig. 23/4).
Oil quantity with oil filter: 3.7 liter.
3. Remove the drain plug and drain the engine oil into the collecting vessel.
4. Disassemble the oil filter (Fig. 23/5) and install a new oil filter with a new sealing ring (tighten hand-tight).
Only use original spare parts!



Dispose of the waste oil and used oil filter according to the applicable environmental regulations!

5. Replace and tighten the drain plug.
6. Fill the engine oil, see paragraph 5.5.1.

5.5.3 Changing the fuel filter

Change the fuel filters (Fig. 23/6) and (Fig. 23/7) every 250 operating hours. The fuel filter (Fig. 23/6) is fixed by means of hose clamps and must be changed as a unit.

The fuel filter (Fig. 23/7) is only installed for diesel engines!

1. Close the fuel filter valve (Fig. 23/8).
2. Remove the filter cover and change the filter insert. Only use original spare parts!



Dispose of residual fuel and used filters according to the applicable environmental regulations!

5.5.4 Venting the fuel system

1. Fill the fuel tank.
2. Use a suitable collecting vessel and open the fuel filter valve.
3. Loosen the vent plugs (Fig. 23/9) on the fuel filter and tighten again when no further air bubbles escape.
4. Loosen the vent plug on the injection pump (Fig. 23/10) and tighten again when no further air bubbles escape.

Maintenance and Care

5.6 Air filter

The air filter is located under the seat console.



Allow the engine to cool down before starting any cleaning and maintenance work. Otherwise you could burn yourself on hot surfaces!

Pay attention to rotating parts in the vicinity of the fan. Risk of injury!

- 1 Dust discharge valve
- 2 Snap-in hooks
- 3 Housing cover
- 4 Upper housing section
- 5 Main filter
- 6 Safety cartridges

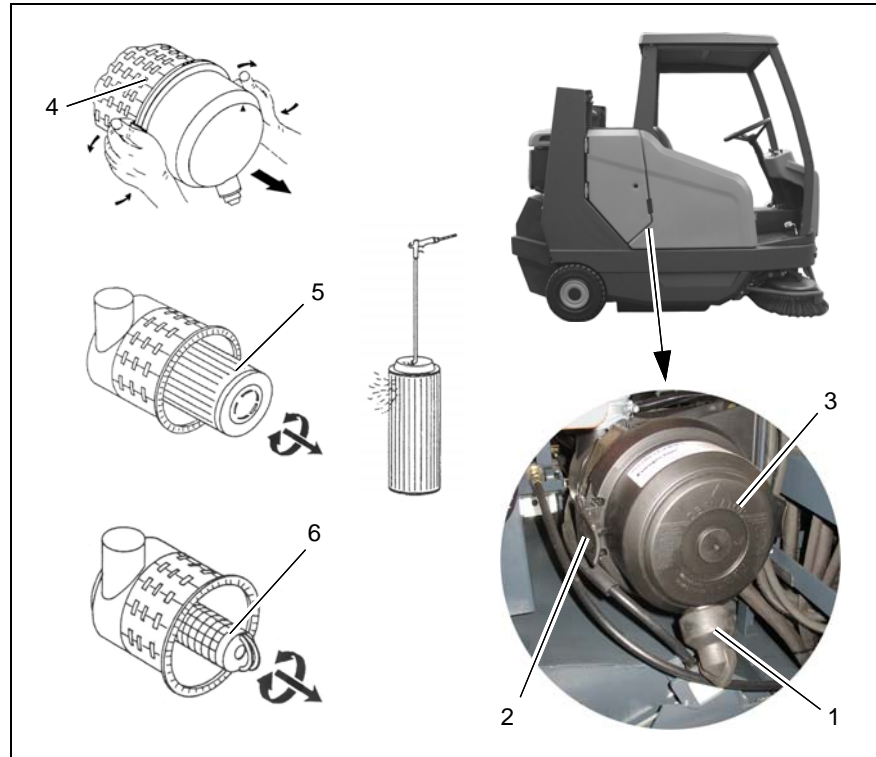

Fig.25

Maintenance and Care

5.6.1 Cleaning the dust discharge valve

The dust discharge valve (Fig. 25/1) must be cleaned every day. Press the valve together, thus, removing the accumulation of dust. Replace the valve if damaged.

5.6.2 Disassembling the main filter

1. Open the seat console, refer to Section 5.4.
2. Unlock the snap-in hooks (Fig. 25/2) holding the housing cover and remove the housing cover (Fig. 25/3).
3. Remove the main filter (Fig. 25/5) out of the upper housing section (Fig. 25/4) by turning it a little.

5.6.3 Cleaning the main filter

The main filter (Fig. 25/5) must be checked each week and cleaned as necessary.

1. Clean the housing cover (Fig. 25/6) on the inside using a moist cloth.
2. Blow the main filter clean from the inside towards the outside with compressed air. Use compressed air to max. 3 bar.
3. Use a source of light to check the main filter for perforations.
4. Check the seals on the main filter for

signs of damage.

5.6.4 Installing the main filter

1. Slide the main filter (Fig. 25/5) back in the upper housing section, with the open side first.
2. Replace the housing cover (Fig. 25/3), pay attention to the correct position of the dust discharge valve.
3. Lock the housing cover back in place with the snap-in hooks (Fig. 25/3).

5.6.5 Changing the main filter

The main filter (Fig. 25/4) must be changed in the case of large accumulations of dirt, damage or every 250 operating hours at the latest.

1. Disassemble the main filter, see paragraph 5.6.2.
2. Insert the new main filter. Only use original spare parts!
3. Install the main filter, see paragraph 5.6.4.

5.6.6 Changing the safety cartridge



The safety cartridge (Fig. 25/6) must not be cleaned nor reused after being disassembled!

The safety cartridge must be replaced every 1000 operating hours at the latest.

1. Disassemble the main filter (Fig. 25/4), see paragraph 5.6.2.
2. Take hold of the safety cartridge on both shackles and pull it while turning slightly.
3. Insert a new safety cartridge (Fig. 25/5). Only use original spare parts!
4. Install the main filter (Fig. 25/4), see paragraph 5.6.4.

Maintenance and Care

5.7 Cooling system

The combined radiator (Fig. 26/1) cools both the cooling water for the engine as well as the hydraulic oil for the work hydraulics. The coolant is cooled in the radiator by means of a fan (Fig. 26/2). If the coolant temperature is too high, it is indicated in the operating panel.



Allow the engine to cool down before starting any cleaning and maintenance work. Otherwise you could burn yourself on hot surfaces!

Pay attention to rotating parts in the vicinity of the fan. Risk of injury!

Never open the radiator when the engine is hot because, when it is, the cooling system is under high pressure. Risk of burns! Wear protective gloves!

- 1 Radiator
- 2 Cap
- 3 Fan
- 4 Draining hose
- 5 Resuction tank

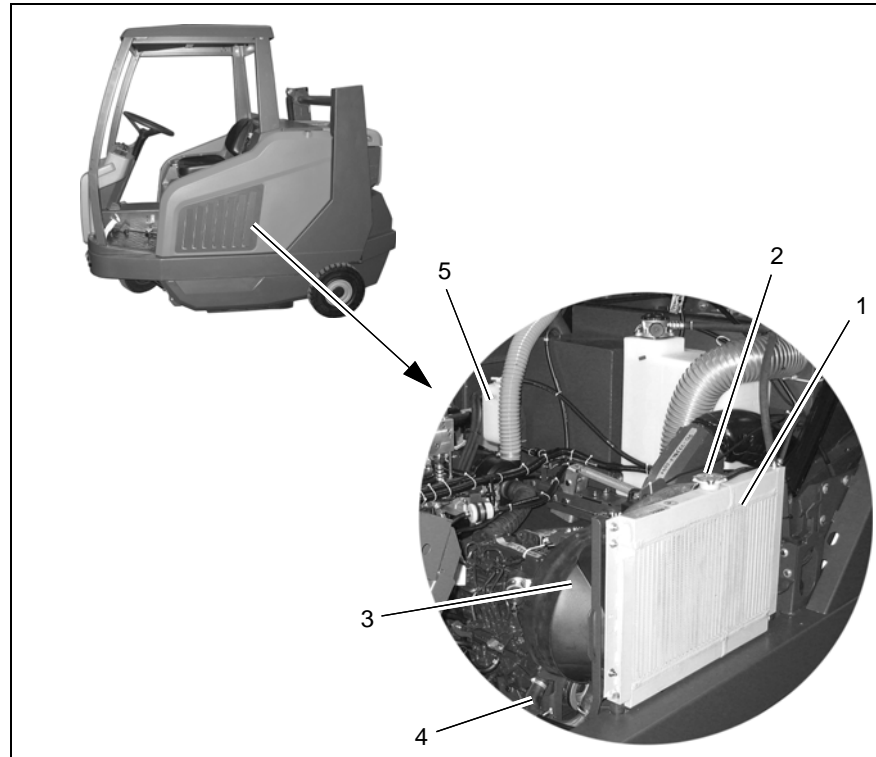

Fig.26

Maintenance and Care

5.7.1 Cleaning the radiator

Check the radiator (Fig. 26/1) daily and clean as necessary. Dirt on the radiator ribs reduces the cooling capacity.



The radiator ribs are very thin and can be easily damaged!

1. Open the seat console, refer to Section 5.4.
2. Clean the radiator ribs with compressed air, blowing from the engine side outwards.

5.7.2 Refilling the coolant

Too little coolant reduces the cooling capacity. Check the coolant level daily through the cap and refill as necessary.



Only use the coolant prescribed, refer to Technical Data. Do not mix with other types! Before the winter season begins, check the concentration of the coolant.

1. When the engine has cooled down, open the cap (Fig. 26/2) carefully.
2. Check the coolant level. The optimal coolant level is achieved when the ribs are covered. Fill slowly, if necessary.

3. Replace the cap.
4. Allow the engine to run for a few minutes.
5. Turn the engine off and allow to cool down.
6. Check the coolant level again and refill, if necessary.



Only refill coolant in the radiator. Do not refill at the resuction tank (Fig. 26/5)!

5.7.3 Changing the coolant

The coolant must be changed every 1000 operating hours at the latest.

1. Place a suitable collecting vessel under the radiator draining hose (Fig. 26/4).
2. Open the draining hose and drain off the coolant fully.
Coolant quantity, approx. 3 liters.



Dispose of the used coolant according to the applicable environmental regulations!

3. Close the draining hose again.
4. Refill fresh coolant, refer to Technical Data.
5. Replace the cap.

6. Allow the engine to run for a few minutes.
7. Turn the engine off and allow to cool down.
8. Check the coolant level again and refill, if necessary.

5.8 Hydraulic system



Work on the hydraulic system may only be carried out by technical experts and correspondingly trained personnel! Hydraulic oil under high pressure can cause severe injuries! Allow the engine to cool down before starting any cleaning and maintenance work. Otherwise you could burn yourself on hot surfaces! Pay attention to rotating parts in the vicinity of the fan. Risk of injury!

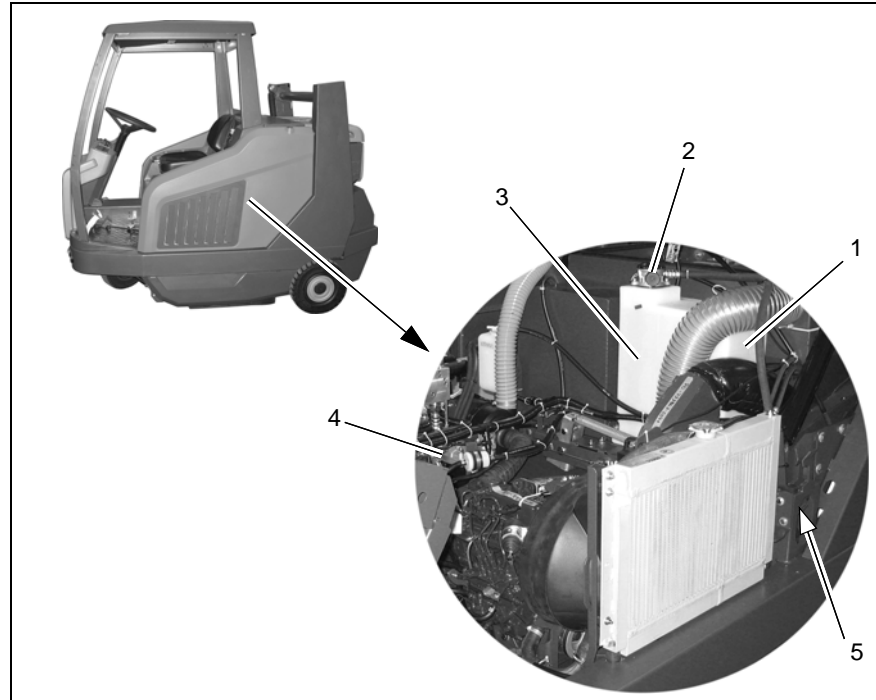

Fig.27

- 1 Fill level indicator
- 2 Cap

- 3 Hydraulic oil tank
- 4 Hydraulic oil filter
- 5 Draining hose

Maintenance and Care

5.8.1 Filling hydraulic oil

Check the oil level of the hydraulic oil tank every day.



Only use the hydraulic oil prescribed, refer to Technical Data! Shortages of hydraulic oil or incorrect hydraulic oil leads to damage to the hydraulic system!

1. Open the seat console, refer to Section 5.4.
2. Check the oil level on the fill level indicator (Fig. 27/1) of the hydraulic oil tank (Fig. 27/3).
3. Remove the cap (Fig. 27/2).
4. Do not pour in too much oil at one time. Measure the oil level again.
5. Check the input filter for cleanliness. Replace the cap.

5.8.2 Changing the hydraulic oil

The hydraulic oil must be changed every 500 operating hours.



Take the utmost care when draining hot hydraulic oil. Risk of burns!

1. Park the vehicle on a level surface and lower the sweepings container.

Switch the engine off and apply the parking brake.

2. Place a suitable collecting vessel under the draining hose (Fig. 27/5) of the hydraulic oil tank.
Oil quantity: 25 liters.
3. Loosen the clips and remove the plug from the draining hose. Allow the hydraulic oil to drain off into the collecting vessel.



Dispose of the used hydraulic oil according to the applicable environmental regulations!

4. Fix the plug and clip to the draining hose and refill hydraulic oil, see paragraph 5.8.1.
5. Start the engine and, when running at a slow speed, put all the work functions into operation and raise and empty the sweepings container several times. Switch the engine off again.
6. Refill more hydraulic oil, if necessary. Check the hydraulic system for leaks.

5.8.3 Change hydraulic oil filter

The hydraulic oil filter must be changed for the first time after 50 operating hours and subsequently every 500 operating hours.



Take the utmost care when draining hot hydraulic oil. Risk of burns!

1. Park the vehicle on a level surface and lower the sweepings container. Switch the engine off and apply the parking brake.
2. Unscrew the hydraulic oil filter (Fig. 27/4).



Dispose of the used hydraulic oil filter according to environmental regulations!

3. Install a new hydraulic oil filter with new sealing rings (tighten hand-tight). Only use original spare parts!
4. Start the engine and switch it off again. Check the hydraulic system for leaks.

5.9 Sweeping unit

- 1 Side brushes
- 2 Rotary brush
- 3 Sweepings container
- 4 Suction turbine
- 5 Filter system

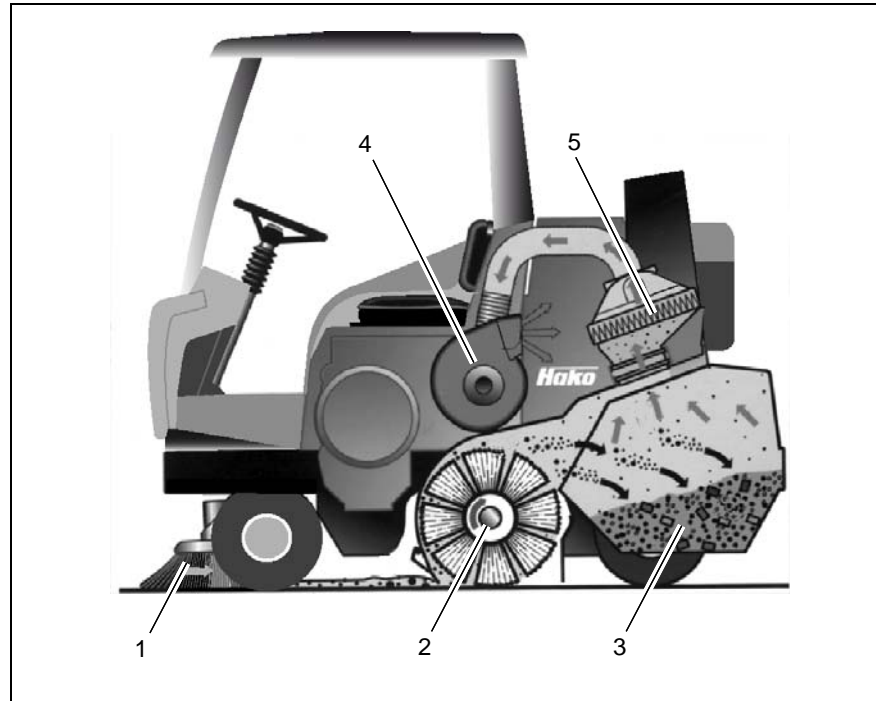

Fig.28

Maintenance and Care

5.9.1 Side brushes

- 1 Adjusting bolt
- 2 Side brushes
- 3 Catch

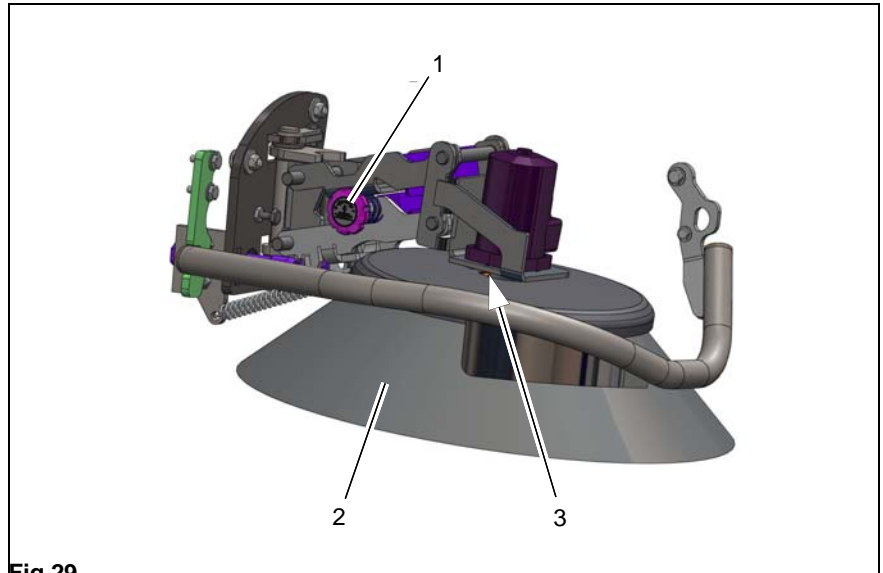

Fig.29

5.9.2 Adjusting the side brushes

Check the side brushes (Fig. 29/2) every week for signs of wear. In the event of wear or after the side brushes have been changed, proceed as follows to complete the necessary adjustments:

1. Park the vehicle on a level surface.
Switch the engine off and apply the parking brake.
2. Adjust the contact surface of the side brush (Fig. 29/2) using the adjusting bolt (Fig. 29/1). The contact surface of the side brush should be approx. $\frac{2}{3}$ of the brush circumference.

5.9.3 Changing the side brushes

When the brushes have worn to a bristle length of 8 cm or less, the side brushes must be replaced.

1. Park the vehicle on a level surface.
Switch the engine off and apply the parking brake.
2. Loosen the screws and washers on the catch (Fig. 29/3) and remove the side brush (Fig. 29/2).
3. Install the new side brush. Only use original spare parts!
4. Adjust the side brush, see paragraph 5.9.2.

Maintenance and Care

5.9.4 Rotary brush

- 1 Rotary brush
- 2 Sealing strip, left
- 3 Sealing strip, front
- 4 Sealing strip, rear
- 5 Sealing strip, right
- 6 Rotary brush half
- 7 Screw connection (5 pieces)
- 8 Crank brush wear
- 9 Scale

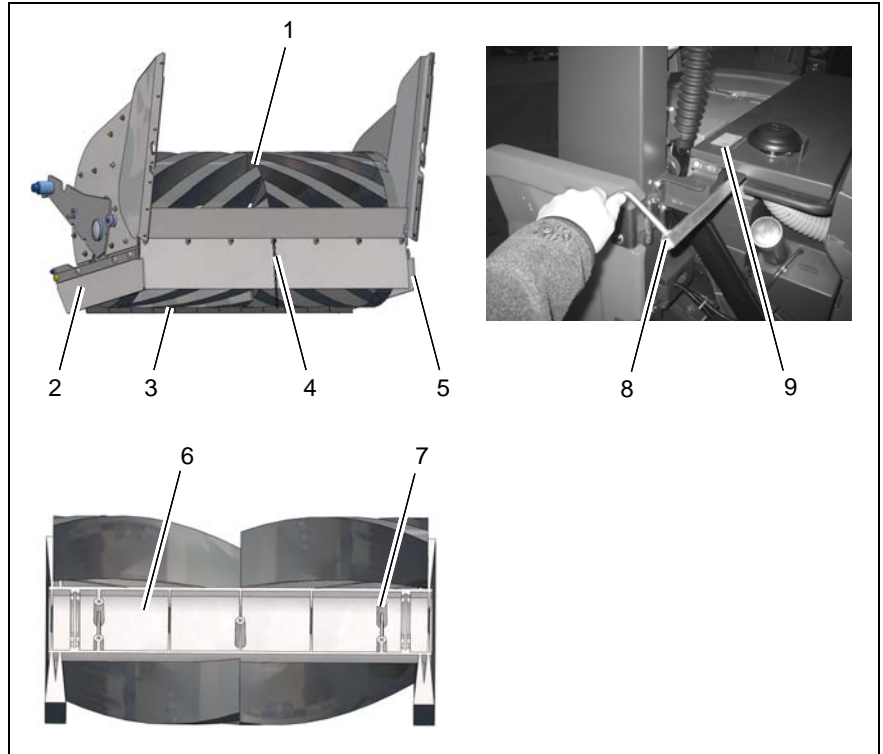

Fig.30

Maintenance and Care

5.9.5 Setting the sweeping pattern

Check the rotary brush (Fig. 30/1) every week for signs of wear. In the event of wear or after the rotary brush has been changed, proceed as follows to complete the necessary adjustments:

1. Lower the rotary brush onto a smooth floor and allow to rotate for a short time while the vehicle has stopped.
2. Raise the rotary brush and drive the vehicle forwards a little.
3. Switch the engine off and apply the parking brake.
4. Check the degree of wear. When setup correctly, the rotary brush must produce a parallel sweeping track, 90 +/- 10 mm wide, on the floor.
5. Fit the crank (Fig. 30/8) on the square and adjust the sweeping pattern.
 - Turn clockwise: smaller sweeping pattern
 - Counterclockwise: larger sweeping patternThe value is indicated on the scale (Fig. 30/9).

5.9.6 Aligning the rotary brush parallel

The rotary brush is set parallel at the factory. If the parallel alignment is no longer set, please contact an authorized Hako service center.

5.9.7 Changing the rotary brush

In the case of wear resulting in a bristle length of at least 100 mm, the rotary brush must be changed. The rotary brush can be accessed from the rear when the sweepings container has been raised and can be disassembled as follows:

1. Park the vehicle on a level area of floor.
2. Switch off the sweeping function.
3. Switch the engine off and apply the parking brake.
4. Turn the rotary brush by hand until the five screw connections (Fig. 30/7) are visible.
5. Loosen the screw connections and remove the rotary brush half (Fig. 30/6).
6. Turn the second rotary brush half further and pull out to the rear (the rotary brush is held by clamps).

7. Install the new rotary brush in the reverse sequence. Only use original spare parts!
8. When assembling the rotary brush, pay attention that the clamps engage in the catches and to the direction of the bristles. The alignment of the bristles must conform to that illustrated in the figure.
9. Adjust the sweeping pattern, see paragraph 5.9.5.

Maintenance and Care

5.9.8 Adjusting the sealing strips

Check the sealing strips in the rotary brush area every week, readjust as necessary.

1. Park the vehicle on a level area of floor.
2. Raise the sweepings container.
3. Switch the engine off and apply the parking brake.
4. The side sealing strips (Fig. 30/2) and (Fig. 30/5) can be adjusted via the slots. The sealing strips must make contact with the floor.
5. The front sealing strip (Fig. 30/3) can be adjusted using an actuating rod. The sealing strip must make contact with the floor and bend slightly to the rear.
6. The rear sealing strip (Fig. 30/4) can be adjusted via the slots. The sealing strip must have a clearance of approx. 5 mm to the floor.

5.9.9 Changing the sealing strips

Check the sealing strips in the rotary brush area weekly for signs of wear, re-adjust as necessary. Replace worn sealing strips.

1. Park the vehicle on a level area of floor.
2. Raise the sweepings container.
3. Switch the engine off and apply the parking brake.
4. Loosen and remove the sealing strips and replace by new ones. Only use original spare parts!
5. Adjust the sealing strips, see paragraph 5.9.8.

Maintenance and Care

5.9.10 Filter system

- 1 Lock
- 2 Cover
- 3 Holder
- 4 Wing bolt
- 5 Frame
- 6 Agitating device
- 7 Dust filter

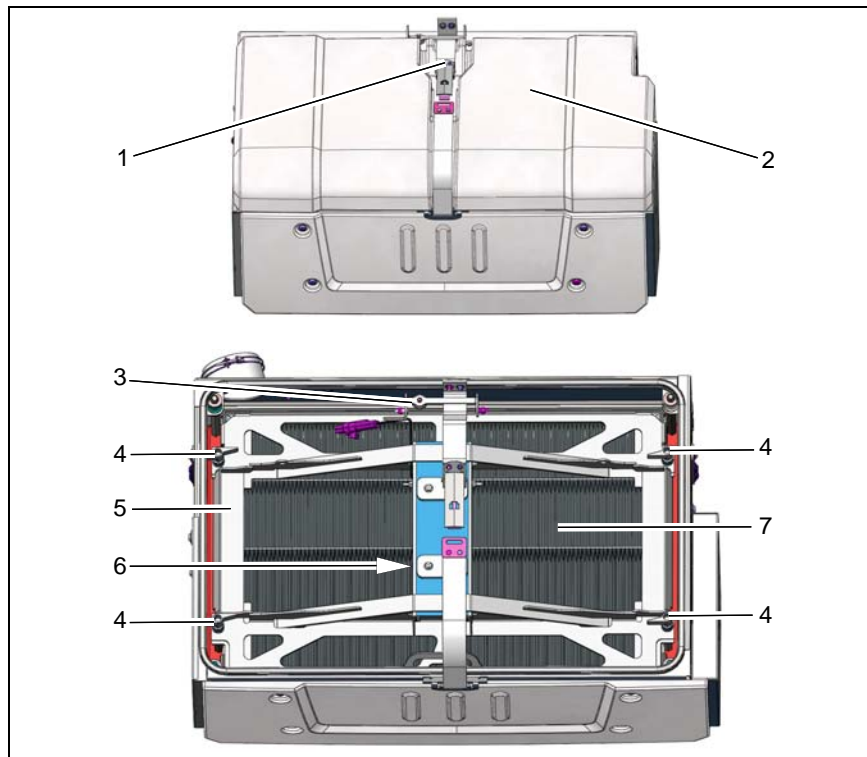

Fig.31

Maintenance and Care

5.9.11 Cleaning the dust filter

The dust filter (Fig. 31/7) is located under the cover (Fig. 31/2). The fine dust swirled up by the rotary brush is drawn into the filter element by the suction turbine. Check the level of dirt in the dust filter weekly.



Clean the dust filter outdoors and wear a dust mask when doing so! Dispose of the dust according to the applicable environmental laws!

1. Park the vehicle on a level area of floor. Switch the engine off and apply the parking brake.
2. Open the lock (Fig. 31/1) on the cover (Fig. 31/2).
3. Loosen the wing bolts (Fig. 31/4), pivot up the frame (Fig. 31/5) with the agitating device (Fig. 31/6) and allow it to engage in the holder (Fig. 31/3).
4. Remove the dust filter (Fig. 31/7).
5. Drop the dust filter horizontally onto level ground from a height of approx. 1 meter (soiled side must face the ground!).
6. Install the dust filter again in the reverse sequence.

5.9.12 Changing the dust filter

1. Park the vehicle on a level area of floor. Switch the engine off and apply the parking brake.
2. Open the lock (Fig. 31/1) on the cover (Fig. 31/2).
3. Loosen the wing bolts (Fig. 31/4), pivot up the frame (Fig. 31/5) with the agitating device (Fig. 31/6) and allow it to engage in the holder (Fig. 31/3).
4. Remove the dust filter (Fig. 31/7).
5. Install the new dust filter in the reverse sequence. Only use original spare parts! Pay attention to the direction of installation, refer to imprint.
6. Check the function of the agitating device.

5.10 Wheels and brakes

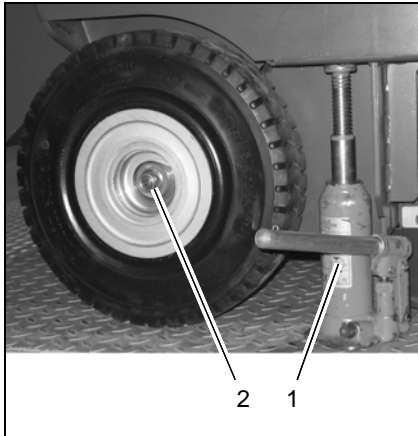

Fig.32

5.10.1 Checking tire wear

Check the tires weekly for signs of wear and tread depth.

5.10.2 Changing tires



Work on the wheels may only be carried out by technical experts and correspondingly trained personnel!

1. Park the vehicle on a level surface and secure against rolling away.
2. Switch the engine off and remove the ignition key.
3. Bring the jack (Fig. 32/1) into position under the frame.
4. Raise the vehicle with the jack.
5. Remove the flange nut.
6. Remove the tires with rims.
7. Mount new tires. Only use original spare parts!
8. Tighten the flange nut at a torque of 50 Nm.

5.10.3 Brakes



Work on the brake system may only be carried out by technical experts and correspondingly trained personnel!

The service brake and parking brake must be checked after the first 50 operating hours and subsequently after every 250 operating hours in use. The brake shoes must be changed every 1000 operating hours.

Maintenance and Care

5.11 Electronics

5.11.1 Fuses

The fuse box (Fig. 33/1) is on the right-hand side of the foot area. The main fuse and pre-fuse are located in the engine compartment in front of the battery.

- F1 Main fuse (50A)
- F2 Pre-fuse (50A)
- F3 Lighting (15A) (option)
- F4 Hazard warning light (10A) (option)
- F5 Flashing beacon (7.5A) (option)
- F6 Heating (30A) (option)
- F7 Spare
- F8 Engine stop relay (15A) (diesel only)
- F9 Indicator (10A) (option)
- F10 Windscreen wipers (7.5A) (option)
- F11 2nd side brush (7.5A) (Option)
- F12 Spare
- F13 Charge control (10A)
- F14 Horn (10A)
- F15 Tail light, left (5A) (option)
- F16 Tail light, right (5A) (option)

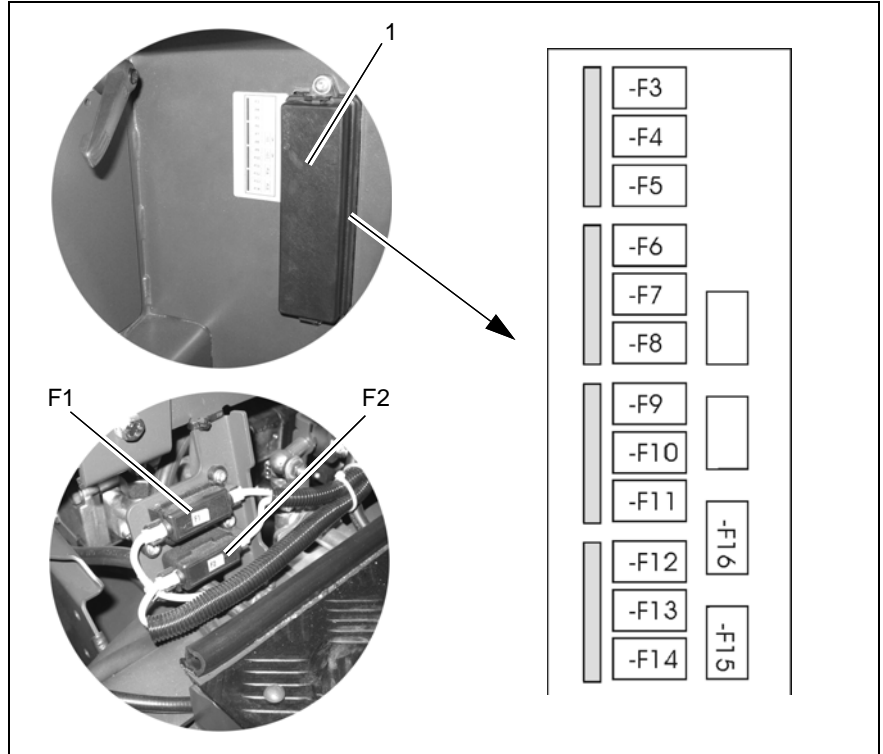

Fig.33

Maintenance and Care

5.11.2 Relays

- K1 Starter release relay,
- K2 Cab relay
- K3 Driving lights relay (option)
- K12 Indicator relay (option)

5.11.3 Changing the battery



The negative pole of the battery (Fig. 34/1) must be disconnected from the battery before the positive pole. This prevents short circuiting and injuries!

1. Park the vehicle on a level area of floor. Switch the engine off and apply the parking brake.
2. First disconnect the negative cable and then the positive cable.
3. Remove the battery.
4. Insert the new battery.
5. First disconnect the positive cable and then the negative cable.

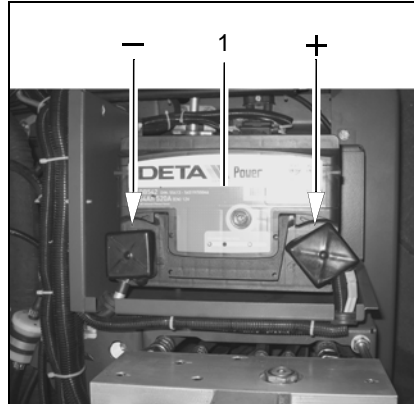

Fig.34

Maintenance and Care

5.12 Special equipment and replacement demands

Name	Description	Order no.
Liquefied petroleum gas system	Attachment kit for liquefied petroleum gas without change bottle	6401
Dual Fuel System	Attachment kit for switching between liquefied petroleum gas/petrol	640110
Cab safety roof	Based on IEC 60335-2-72 CC	6474
Cab paneling	Only in connection with the cab safety roof	647402
Cab heating	Only in connection with the cab safety roof	647404
Side brush, left	Supplied with standard brushes	6486
Flashing beacon	On pole, for assembly without a cab safety roof	643302
Flashing beacon	For assembly on a cab safety roof	643312
Lighting system	To light the working area (in accordance with StVZO - road traffic licensing regulations)	643112
Working lights	2 pieces, integrated at the front of the vehicle frame	643412
Spare rotary brush	With PP bristles, hard bristles, standard	6457
Spare rotary brush	With PES bristles, soft bristles	6413
Spare rotary brush	With PA bristles, hard bristles	6455
Spare side brush	PA bristles (PA 1.5) middle bristles	6414
Spare side brush	PA bristles (PA 2.0), standard	6423
Spare side brush	PES bristles, soft bristles	6415

Maintenance and Care

EC Declaration of Conformity (corresponds to EC Directive 2006/42/EC)

Hako GmbH
Hamburger Straße 209-239
D-23843 Bad Oldesloe

declares that the product

Sweepmaster P1500 RH
Typ: 6464.10
Sweepmaster D1500 RH
Typ: 6464.30

to which this declaration relates, conform to the relevant provisions of the safety and health requirements stipulated in EC Directive 2006/42/EC and is in accordance with 2004/108/EC.

Reference was made to the following standards and/or norms and/or technical specifications to ensure proper implementation of the safety and health requirements in the EC Directive:

DIN EN 60335-2-72
DIN EN 61000-6-2
DIN EN 55012

Bad Oldesloe, 22.04.2014



Dr. Rainer Bavendiek
Director R&D

Name of the authorized person who compiles technical documents for Hako:

Ludger Lüttel

Hako

Clean ahead

Spitzentechnik für eine saubere und schönere Umwelt

Advanced Technology for a Cleaner, Better Environment



Hako GmbH • Hamburger Str. 209-239 • D-23843 Bad Oldesloe
☎ +49 4531 806-0 • Fax +49 4531 806-338

88-10-2900 - 3100-11