

Technical data

	Multicar M31 T	Multicar M31 B	Multicar M31 C	Multicar M31 H
Engine and transmission				
Engine	IVECO F 1 C turbo diesel			
Capacity	2998 cm ³			
Power output	107 kW (145 hp) at 3500 rpm			90 kW (122 hp) at 3.000 rpm
Max. torque	320 Nm at 1400 rpm			310 Nm at 1.250 rpm
Pollutant emissions	Exhaust emissions according to Euro 5 standard – closed-system particle filter			
Transmission	5 forward gears and 1 reverse gear; with all-wheel drive incl. crawling gear: 10 forward gears and 2 reverse gears			
Handling characteristics				
Speed range N2	0-90 km/h			0-70 km/h
Chassis	Flexible, modular-constructed and light-weight sheet-steel frame			<ul style="list-style-type: none"> Hydraulic driving mode: 0-70 km/h
Wheelbase	2,450 (short), alternatively 2,930 (long)			<ul style="list-style-type: none"> Hydraulic working mode: 0-34 km/h
Axles, front suspension	Independent suspension with telescopic shock absorber and additional coil springs			<ul style="list-style-type: none"> Crawling gear level 1 0-40 km/h
Axles, rear suspension	Telescopic shock absorber with additional progressive flat springs			<ul style="list-style-type: none"> Crawling gear level 2 0-17 km/h
Tyres	225/75 R 16 C (standard), additional tyres optionally available			
Driver's cab	Tilting space frame cabin			
Drive and control unit				
Drive	4x2, 4x4 on-demand all-wheel drive optionally available		Selectable 4x4 all-wheel drive (series production)	
Clutch	Hydraulically actuated, asbestos-free			
Steering	Power-assisted steering			
Tank volume	80 litres			
Brakes	4-wheel disc brakes (ventilated) with 4-channel ABS			
Load values				
Maximum permissible weight	up to 5.6 t			up to 5.7 t (at 70 km/h)
Max. axial load front	2.4 t			
Max. axial load rear	up to 3.8 t (depending on the speed)			
Max. payload 4x2 drive*	3.1 t (short wheelbase) 2.9 t (long wheelbase)	Equipment and model dependent	-	-
Max. payload 4x4 drive*	2.9 t (short wheelbase) 2.7 t (long wheelbase)	Equipment and model dependent	Equipment and model dependent	Equipment and model dependent
Permissible trailer weight	3.5 t (brake-assisted), 0.75 t (non break-assisted)			
Gross combination weight rating	7.5 t			
Hydraulics				
Electrical tipping hydraulics	Max. 5 l/min Max. working pressure 150 bar	-	-	-
1-circuit hydraulics	-	Max. 45 l/min Working pressure 200/245 bar**	-	-
3-circuit universal hydraulics	-	-	Max. 80 l/min, max. working pressure 200 bar	Max. 80 l/min, max. working pressure 200 bar
3-circuit high-pressure comfort hydraulics	-	-	Max. 80 l/min, max. working pressure 300/200 bar	Max. 80 l/min, max. working pressure 300/200 bar
Option summation circuit			max. 110 l/min, max. working pressure 300 bar	

* Optional extras reduce the payload; ** with reinforced rear axle and skip loader. Form, colour and design are subject to change in favour of further technical development. Images may display optional extras.

Multicar M31, unbodyed

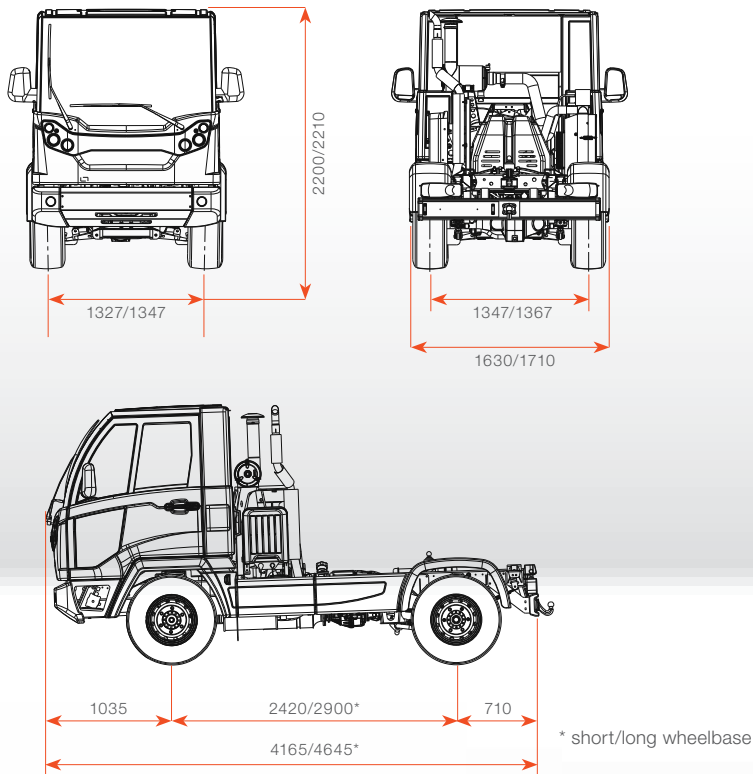

You can always count on a Multicar

Benefit from professional expert advice, top product quality and our attractive financing & leasing options and profit from our excellent after-sales service, providing 24/7 on-site customer service, always close by!

Multicar M31 with body

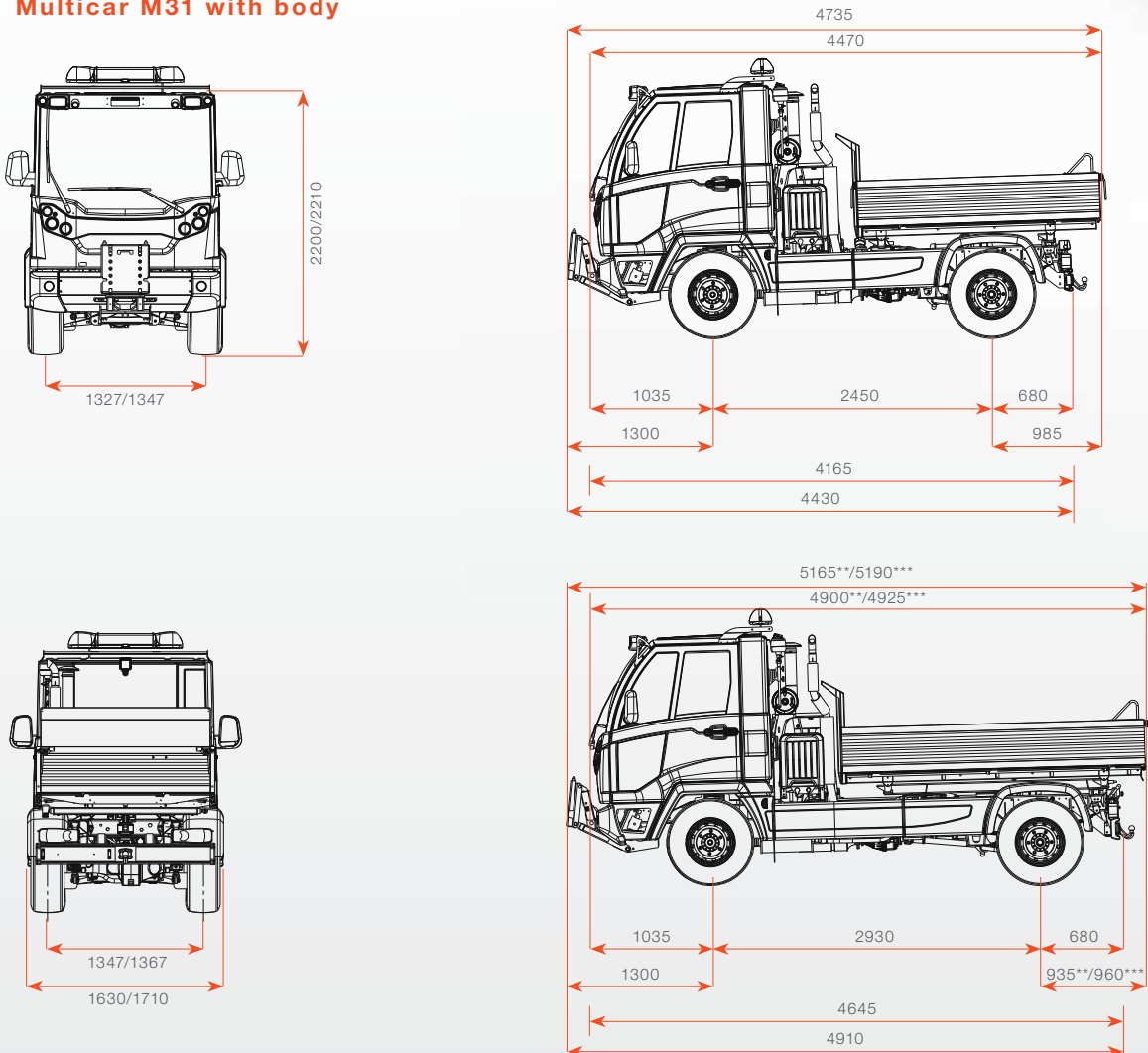

**with body MA 11.3
***with body MA 11.4